



PRODUCT CATALOGUE

Laboratory furniture • Accessories • Consumables • Reagents

medlak
—EQUIPOS DE LABORATORIO Y MÉDICO—



medlak

—EQUIPOS DE LABORATORIO Y MÉDICO—

CONTENT

About us	2	ACCESSORIES FOR SERVICE UNITS	42
Short history	3	05.STORAGE UNITS	48
Relevant standards	4	UNDER BENCH CABINETS	50
01.MODULAR BENCH SYSTEMS	6	SUSPENDED CABINETS	53
H FRAME SYSTEM	8	FREESTANDING CABINETS ON PLINTH	54
C FRAME SYSTEM	9	ACCESSORIES FOR STORAGE UNITS	56
ECO-PLYNTH SYSTEM	10	06.REAGENTS STORAGE UNITS	58
BALANCE TABLE	11	Aspirated and filtered safety cabinets for the storage of chemical, acid and base products	60
MOBILE BENCH	12	Storage units for flammables /organic solvents /explosive volatile reagents	62
02. SINK UNITS /Module sanitaire	14	Combined safety storage cabinets, both for flammables and acids	64
ACCESSORIES FOR SINK UNITS	17	Safety cabinets for gas cylinders indoor storage	66
03.WORKTOPS	20	Custom storage cabinets for low concentrated reagents	68
Ceramic	22	Custom storage cabinets for pesticides and phytosanitary chemicals	69
Epoxy resin	23	07.CHEMICAL FUMEHOOD	70
Vitrous enamel steel	24	08.LABORATORY CHAIRS	74
Polypropylene	25		
Acid-proof solid-grade HPL laminate	26		
Melamine (optional – acid-proof)	27		
Stainless steel	27		
Quartz engineered stoneware	28		
Mineral composite	29		
04.SERVICE UNITS	30		
MINIMAL SYSTEM	32		
MEDIUM SYSTEM	34		
CONSOLES	36		

Medlak (Spain) supplies a wide range of laboratory furniture items, such as:

- Laboratory workbenches (they come in above 30 standard dimensions, and can be equipped with 10 different work tops /surfaces). All our workbenches are produced according the EN 13150:2004 norm.
- Weighing /balance tables.
- Laboratory storage units: Under bench (fixed or on wheels), freestanding or wall mounted (they can be produced in several materials upon request, always complying with the EN 14727 norm).
- Washing /sink units, different by size, materials and application.
- Service panels (media channels) complete with power sockets, water and gas laboratory taps, LED lamps and other holders.
- Custom laboratory chemical fumehoods - 4 standard sizes according to EN 14175 and various exhaust /filtration systems on request.
- Safety cabinets - for acids and other chemical reagents (produced according EN 14727 and EN 1-61010 norms), for flammable and explosive products (produced according EN 14727 and EN 1-14470 norms), for compressed gas cylinders (produced according EN 14727 and EN 2-14470 norms).
- Emergency laboratory showers, freestanding or bench mounted (produced according EN 15154 norm).
- Water taps, flammable and technical gas taps - EN 13792 approved.
- Laboratory chairs and stools, with up to -5year warranty.
- Office furniture, waiting and meeting rooms, lockers, step-over benches, storage cabinets and shelves.

Medlak can provide design and planning, 3D drawings and plans for all projects.





Relevant standards for the laboratory furniture industry and for all Medlak furniture:

Workbenches for laboratories
Dimensions, safety requirements
and test methods

EN 13150

Laboratory furniture
Recommendations for design and installation

EN 14056

Laboratory furniture
Storage units for laboratories
Requirements and test methods

EN 14727

Color code for taps and valves
used in laboratories

EN 13792

Special storage cabinets for flammable
and explosive products

EN 14470

Fire safety storage cabinets
Safety storage cabinets for flammable liquids

EN 14470-1

Fire safety storage cabinets
Safety cabinets for pressurised gas cylinders

EN 14470-2

Office furniture. Office work chairs

EN 1335

Part 1 – Dimensions

EN 1335-1

Part 2 – Safety requirements

EN 1335-2

Part 3 – Test methods

EN 1335-3

Safety requirements for electrical
equipment for measurement, control
and laboratory use

EN 61010





01

MODULAR BENCH SYSTEMS

Workbenches for laboratory use – modular systems with metal frames or structural under bench storage units.

The **Mediak** Collection offers a variety of construction systems and table worktops, perfect for designing fully functional and ergonomic laboratory spaces, for chemistry laboratories, microbiology, and more.

By assembling and fitting with other pieces of furniture such as service panels, cabinets or washing units, the modular systems can workup complex bench compositions with linear or central layout, equipped with all the utilities and accessories needed to conduct proper laboratory work.

All construction systems are equipped with leveling adjustment mechanism and some systems have a load bearing capacity of up to 175 Kg /ml.

For fine weighing, the special tables are provided with an anti-vibrating countertop area, perfectly calibrated and isolated from the rest of the construction.



MODULARITY · ERGONOMICS · OPTIMAL USE OF SPACE · COUNTERTOPS MADE OF CERTIFIED MATERIALS

There are several laboratory workbench systems, with construction typologies, suitable for various lab activities:

- H Series** ● Robust workbench with "H" type metal frame, load bearing capacity up to 175 kg /ml.
- C Series** ● Robust workbench with "C" type metal frame, load bearing capacity up to 150 kg /ml.
- Eco series** ● Laboratory workbench with structural under bench storage units.
- Balance table** ● Weighing tables /table stands for vibration sensitive laboratory equipment.
- Mobile table** ● Mobile workbenches with metallic frame on castors.

H FRAME SYSTEM

Modular bench system with side "H" shaped metal frames and connecting joists.

All metal elements are epoxy powder-coated.

This constructive system has a load bearing capacity of up to 175 Kg for every linear meter .

Various storage cabinets with doors and drawers, mobile or fixed - with rigid grip on the metallic table frame, can be placed under the worktop.

By assembling and fitting with other pieces of furniture such as service panels, cabinets or washing units, this modular systems can workup complex bench compositions with linear or central layout, equipped with all the utilities and accessories needed to conduct proper laboratory work.

Worktop of various materials for laboratory use.

INTENDED USE: Support stand for various laboratory equipment /equipment of large size and weight or as workbench for various regular laboratory activities.

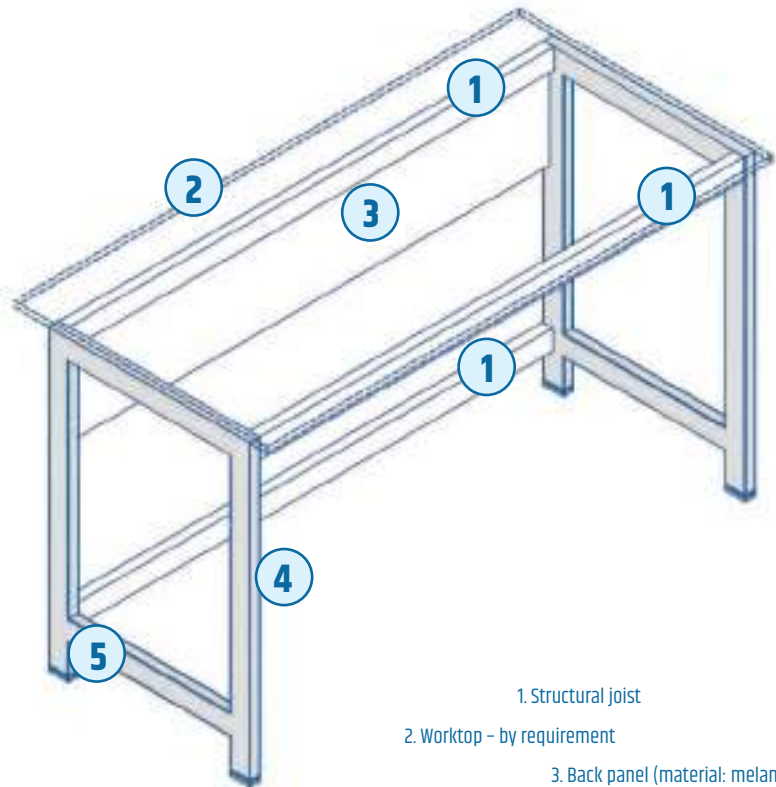

- 1. Structural joist
- 2. Worktop - by requirement
- 3. Back panel (material: melamine)
- 4. "H" frame (material: metallic frame epoxy powder-coated)
- 5. Leveling feet (material: plastic)

Standard sizes

Length	600, 900, 1200, 1500, 1800
Width	600, 750, 900
Height	750, 900
Load bearing capacity	175

C FRAME SYSTEM

Modular bench system with side "C" shaped metal frames and connecting joists.

All metal elements are epoxy powder-coated.

Various storage cabinets with doors and drawers, mobile or fixed – with rigid grip on the metallic table frame can be placed under the worktop.

The shape of the supporting frames allow placing under bench storage with continuous alignment.

By assembling and fitting with other pieces of furniture such as service panels, cabinets or washing units, this modular systems can workup complex bench compositions with linear or central layout, equipped with all the utilities and accessories needed to conduct proper laboratory work.

Worktop of various materials for laboratory use.

INTENDED USE: Support stand for various laboratory equipment /equipment of large size and weight or as workbench for various regular laboratory activities.

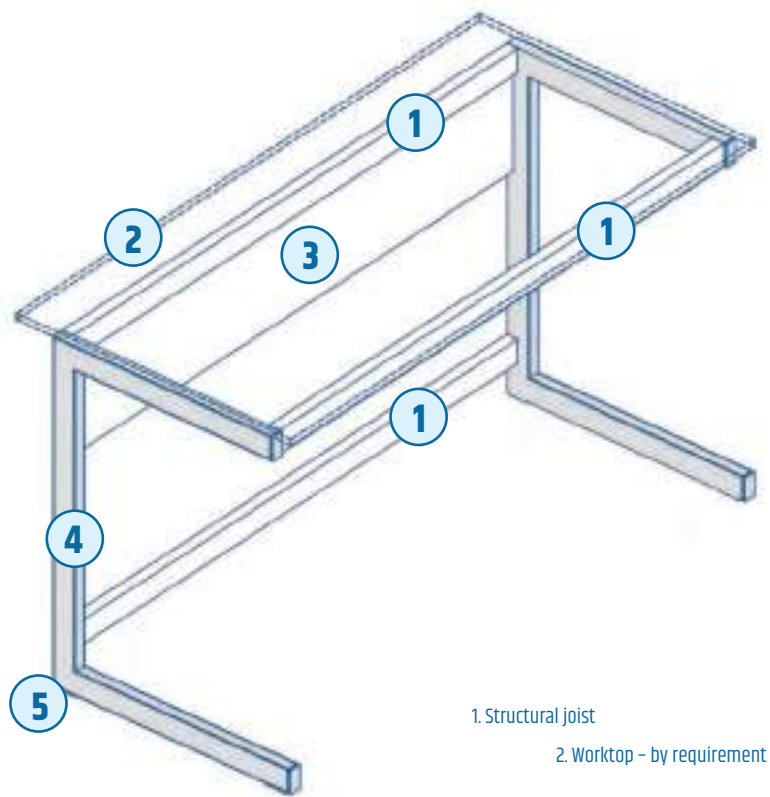

1. Structural joist

2. Worktop – by requirement

3. Back panel (material: melamine)

4. "C" frame (material: metallic frame epoxy powder-coated)

5. Leveling feet (material: plastic)

Standard sizes

Length	600, 900, 1200, 1500, 1800
Width	600, 750
Height	750, 900
Load bearing capacity	150



ECO-PLYNTH SYSTEM

Modular bench system with fixed storage cabinets under the worktop.

Depending on the size of the worktop, it requires a minimum of two structural cabinets to support the top, covering the entire space under the counter, or only partially, leaving working place for the user sitting on the chair (minimum 600 mm).

Worktop of various materials for laboratory use.

INTENDED USE: Recommended as regular laboratory workbenches and support-tables for various laboratory equipment.

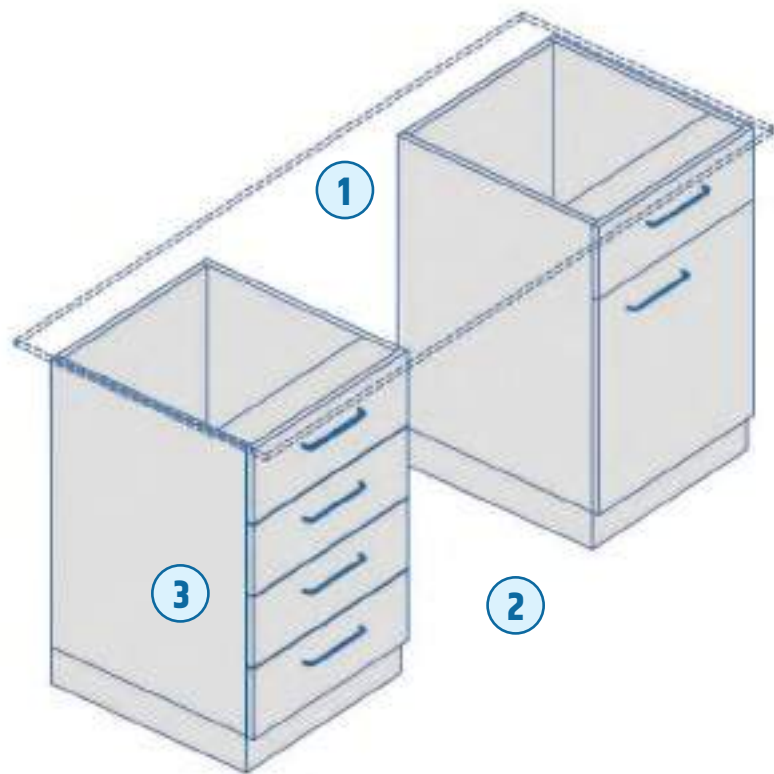

Standard sizes (mm)

Length	600, 900, 1200, 1500, 1800
Width	600, 750, 900
Height	750, 900
Load bearing capacity (kg/ml)	140

1. Worktop - by requirement

2. With storage space covering whole under worktop area, or with gaps for user legroom

3. Self-supporting under bench cabinet on plinth.

One complete freestanding unit requires a minimum of two under bench storage cabinets

BALANCE TABLE /MASĂ DE BALANȚĂ

Weighing table with special worktop and integrated vibration-proof plate with heavy underlayer of fine concrete.

Inner metallic frame vibration decoupled.

For setting up analytical balances and other sensitive measuring equipment.

The table casing with writing area on one side is freestanding and does not touch the weighing surface.

Legroom for user when in use.

INTENDED USE: Supporting table for analytical balance and other vibration sensitive measuring equipment.

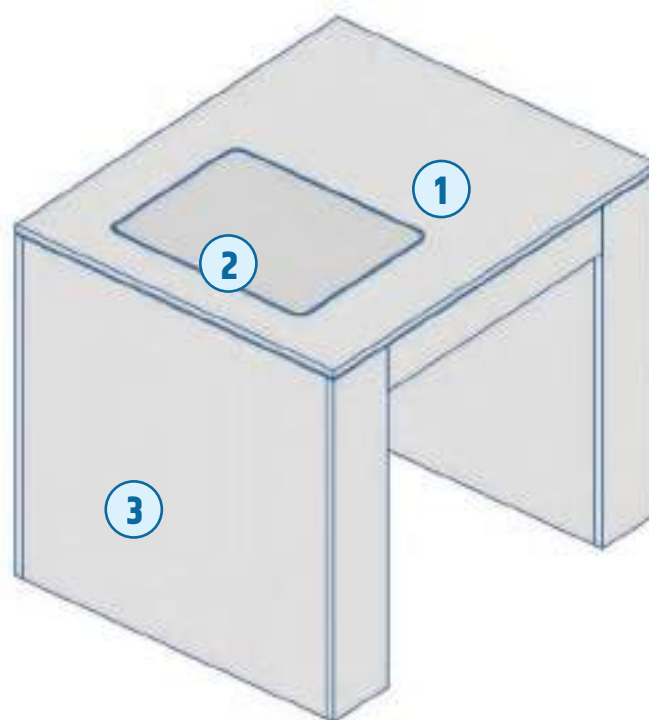

1. Worktop in HPL solid-grade laminate

2. Weighing plate in quartz stoneware with heavy balance underlayer in fine concrete and inner vibration decoupled steel frame

3. Casing in melamine panels

Standard sizes (mm)

Length	900
Width	750, 900
Height	750, 900



MOBILE BENCH

Castor mounted bench with metallic epoxy powder-coated frame.

Workbench for everyday laboratory practice and supporting construction for analytical equipment and structures.

The castors have a double-roller rubber surface with locking mechanism, high bearing capacity to static and dynamic load, so the tables can be easily moved.

Worktop of various materials for laboratory use

INTENDED USE: Recommended as regular work tables in the laboratory and support tables for various devices and equipment.

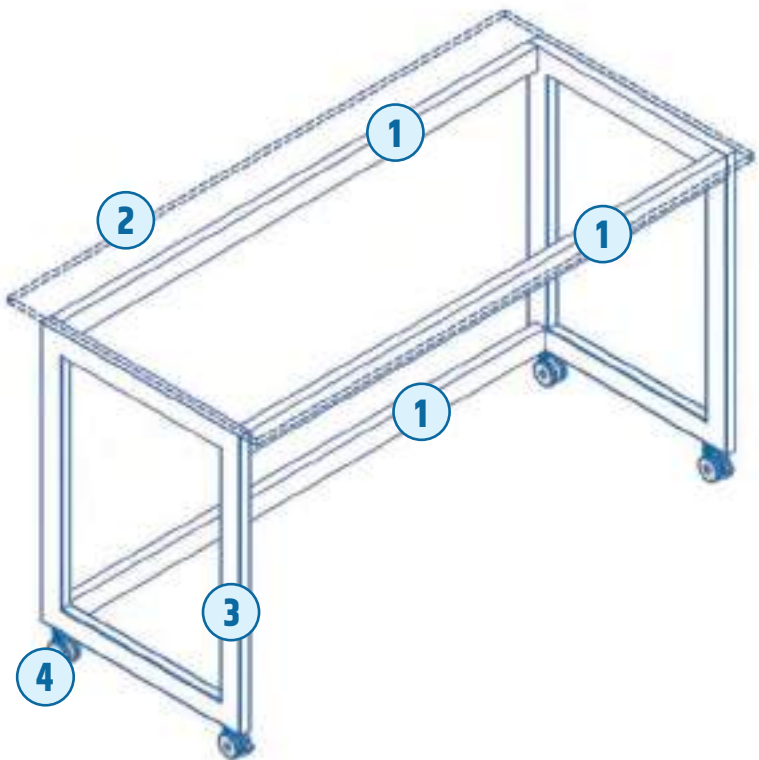

Standard sizes (mm)

Length	600, 900, 1200, 1500, 1800
Width	600, 750, 900
Height	750, 900
Load bearing capacity (kg / ml)	175

- 1. Structural joists
- 2. Worktop – by requirement
- 3. "H" frame (material: metallic frame epoxy powder-coated)
- 4. Heavy load castors with intense traffic rubber rolling surface





SINK UNITS

Washing stands with one or more sinks, integrated in special countertops with anti-splash panels and under counter storage.

In order to have maximum functionality and to protect both the user and the surrounding equipment and furniture, in laboratories, the washing units area must meet certain requirements.

Laboratory sinks, available in several dimensions, are integrated into worktops with specially shaped anti-drip edges (optional).

The taps for water or demineralised water are made of special anti-corrosion materials and are wall mounted or installed on the worktop.



MODULARITY • ERGONOMICS • OPTIMAL USE
OF SPACE • WATERPROOF • SPLASH-PROOF

To avoid splashing and damage to surrounding furniture and equipment, sanitary units can be equipped with splash-proof panels on both the back of the unit and on the sides.

Under the worktop, the washing units have a special fixed furniture body, made of waterproof materials and which can be equipped with custom storage units on plinth, with doors and /or drawers.

The sink units are built in the same parameters of EN 13150 and EN 14727 standards, preserving the design line and ergonomics in the laboratory.

SINK UNITS

Furniture units with special worktops, anticorrosive taps for water, sinks and undertop cabinets for storage. They can be integrated into linear island modular compositions, separating the laboratory wash area.

Depending on the size, the washing units can be equipped with one or two sinks, and with one or more taps for water or ultra-pure water for glassware washing or supplying various laboratory equipment with water.

Optionally, the worktop where the sinks are incorporated may have anti-drip overlapped profile edge.

Both at the back, at the wall and on sides, units can be equipped with splash-proof panels.

INTENDED USE: For areas in which equipment is connected to water supply and drainage. For cleaning laboratory glassware and equipment.

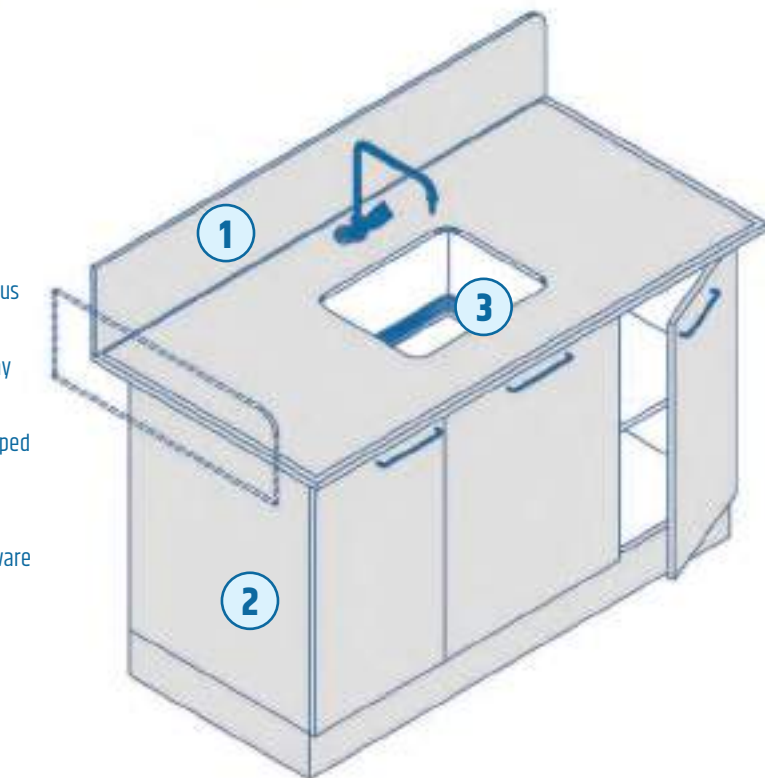

1. Back and side splash panel made in HPL solid-grade laminate isolating the washing area

2. Under bench storage unit with doors, shelves and sink cover, made in water repellent panels

3. Acid-proof water outlet and sink mounted on an acid-proof worktop, with or without anti-drip edge

Standard sizes (mm)

Length	600, 900, 1200, 1500, 1800
Width	600, 750, 900
Height	750, 900

ACCESSORIES FOR SINK UNITS

ACCESORII PENTRU MODULI SANITARE

EMERGENCY EYE SHOWER

Wall mounted or installed on worktop, mono or biocular cups, with extractible hose and /or collecting tray.

SURFACE PROTECTION

Epoxy painted /Nichel plating

MATERIALS

Brass /ABS
Stainless steel /EPDM

HEADWORK SEALING

PTFE temperature working range: 0-70°

CONNECTION TAP

G 1/4" female, G 3/4" female, Swivelling nut G 1/2" female



32100MDS

Single nozzle bench spray unit vertical extracting, bench top mounted (optional - wall mounted)

Flow rate : 7 L /min
Pressure : 5 Bars

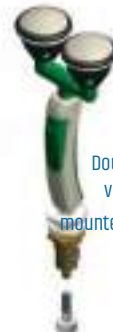

32301MDS

Double nozzle bench spray unit vertical extracting, bench top mounted (optional - wall mounted)

Flow rate : 14 L /min
Pressure : 5 Bars



31700MDS

Wall mounted emergency eye shower

Flow rate : 16 L /min - Pressure : 10 Bars



31500MDS

Floor fixed combined emergency eye-body shower

Flow rate / 50 L /min
Pressure /: 10 Bars



31600MDS

Floor fixed emergency eye shower

Flow rate : 16 L /min
Pressure : 10 Bars

ACCESSORIES FOR SINK UNITS

GLASSWARE DRYER

Glassware drying panel with interchangeable pins, tray and drain hose.

Wall mounted, installed nearby washing areas in the laboratory.

Entirely made of polypropylene, is equipped with 72 various sizes pins.

At the lower side is equipped with tray and flexible drip hose.

1. PP interchangeable pins

2. PP back panel

3. Collecting tray

4. Drip hose

Standard sizes
450x110x630 mm

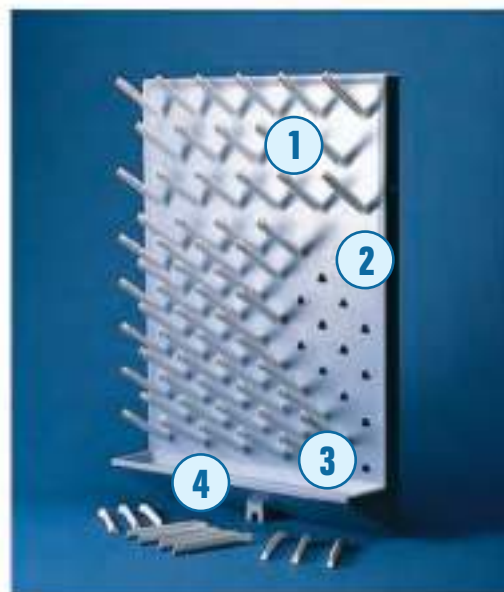

COLLECTOR TANK WITH LEVEL SENSOR AND ACOUSTIC ALARM

Full acid-proof container made of PP (for storage of acid /corrosive solutions) or metallic (for solvents /petroleum products), equipped with level sensor and sound alert when container is full. The tank is tapped at the bottom for emptying.

INTENDED USE: For placing under laboratory draining sinks in order to collect waste substances that cannot be discharged into the sewer or for sanitary units when there is no connection to the sewer. Ideal for mobile /autonomous sanitary units or washing stations in autolaboratories.

Standard dimensions /characteristics:

Custom sizes, depending on the size of the body in which it is installed.



1. Collecting pipe

2. Tank body

3. Drain tap



WORKTOPS

Worktops in materials with special characteristics and shapes, suitable for various laboratory activities.

Choosing the table worktop is one of the most important aspects to be considered in a lab.

Because working in a laboratory often involves using hazardous substances that stain or are highly corrosive, the furniture used, especially worktops are highly exposed and can be easily damaged. For maintaining their function and appearance for as long as possible, it's recommended worktops are chosen carefully, even tested before furnishing the laboratory.

The worktops vary both in standard sizes, physical properties, and behavior in contact with chemicals – diluted or concentrated reagents.

Worktop materials have different behavior when exposed to mechanical shocks, abrasion, high temperatures or wet conditions.



MODULARITY · ERGONOMICS · ACID-PROOF
MOISTURE RESISTANCE · SCRATCH RESISTANCE
MECHANICAL AND THERMAL RESISTANCE

There are 10 materials for laboratory tops available,
each with unique properties:

- Ceramic
- Epoxy resin
- Vitreous enamel steel
- Polypropylene
- Acid-proof solid-grade HPL laminate
- Multilayer melamine (optional - acid-proof)
- Stainless steel
- Quartz engineered stoneware
- Mineral composite

Ceramic

Monolithic mold-casted ceramic top with acid-proof glazed enamel, with overlapped marine edge, molded from the same material, on one or more edges (optional).

The acid-proof coating covers the horizontal surface, the edges of the worktop (optional), and the edges of the cutouts for sinks.

The worktop can stand various but limited cutouts and /or technological holes (optionally glazed).

Also, can incorporate sinks with same properties, mounted in various ways: over the worktop, level with the counter, or hidden (under the worktop).

INTENDED USE:

Recommendations:

- Worktop recommended in highly corrosive work environments where concentrated acids and high temperatures are used.
- The enamel is non-porous and resists up to 24 h without visible changes when in contact with most concentrated reagents.
- Ceramic countertops are monolithic, with optional anti-drip profiled overlapped edges, and can integrate one or more sinks made of the same material.

Strengths:

- Mold-casted overlapped marine edge – cast (not applied /glued).
- Sinks made of the same material.
- The best chemical resistance.
- Extremely good behavior in contact with detergents /disinfectants /dyes.
- The best thermal resistance.

Weaknesses:

- Low resistance to shocks – enamel can be scratched or damaged.
- High specific weight.
- Limited possibility of non-standard sizes and cutouts, technological holes, shapes.

Standard sizes (mm)

Thickness	20
Overall thickness	28,38

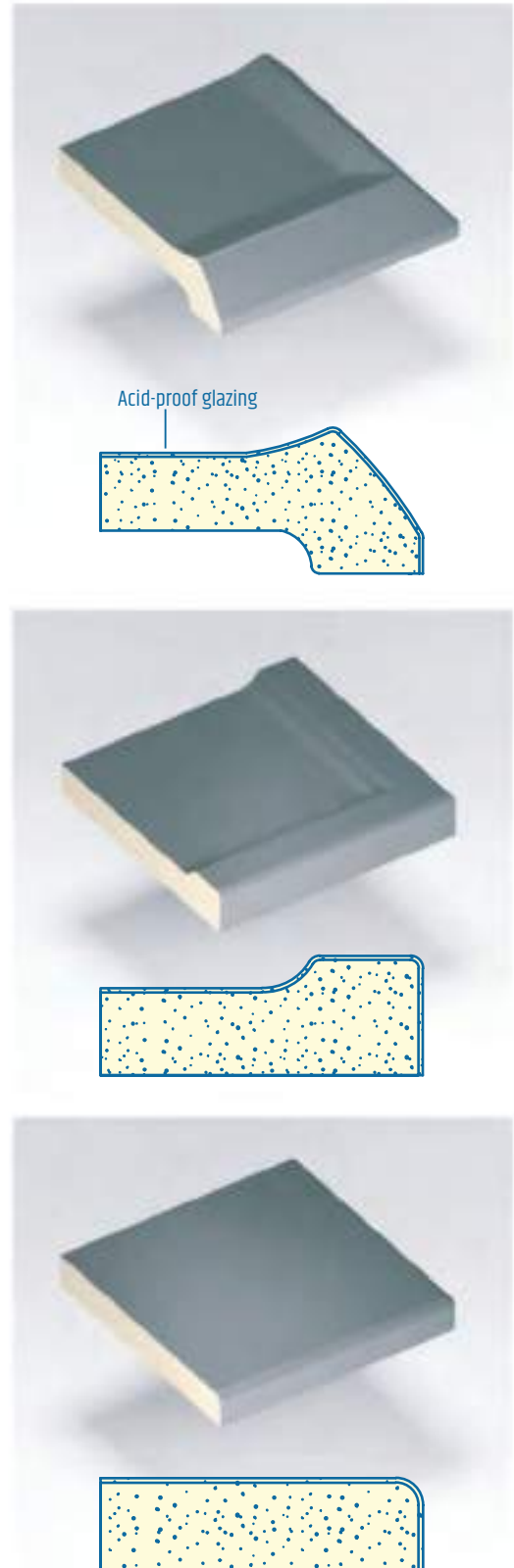

Epoxy resin

Epoxy resin – the same material in both – the mass and the surface of the worktop. The edges of the tops can be flat (slightly rounded) or overlapped, anti-drip edges of the same material.

Epoxy resin tops can include sinks made from the same material, can support various cutouts and /or technological holes and can be polished, for work surface renewal.

INTEDED USE:

Recommendations:

- Monolithic worktop, recommended in laboratories where organic solvents and various petroleum products are used.
- The epoxy resin counter has a very good chemical resistance and best behavior when in contact with high temperatures /surfaces.
- It is a fireproof and durable material – because this type of worktop is mold-casted and has the same material both on surface and in its body, the surface can be renewed by polishing.

Strengths:

- Overlapped edges of the same material.
- Sinks made of the same material – available in many standard sizes.
- The surface of the worktop is renewable by polishing.
- Very good chemical resistance.
- Best thermal resistance – no visible changes when in contact with red heated iron.
- Free dimensioning – non-standard dimensions.

Weaknesses:

- Low resistance to abrasion and shocks.
- Anti-drip overlapped edge is glued, not casted.

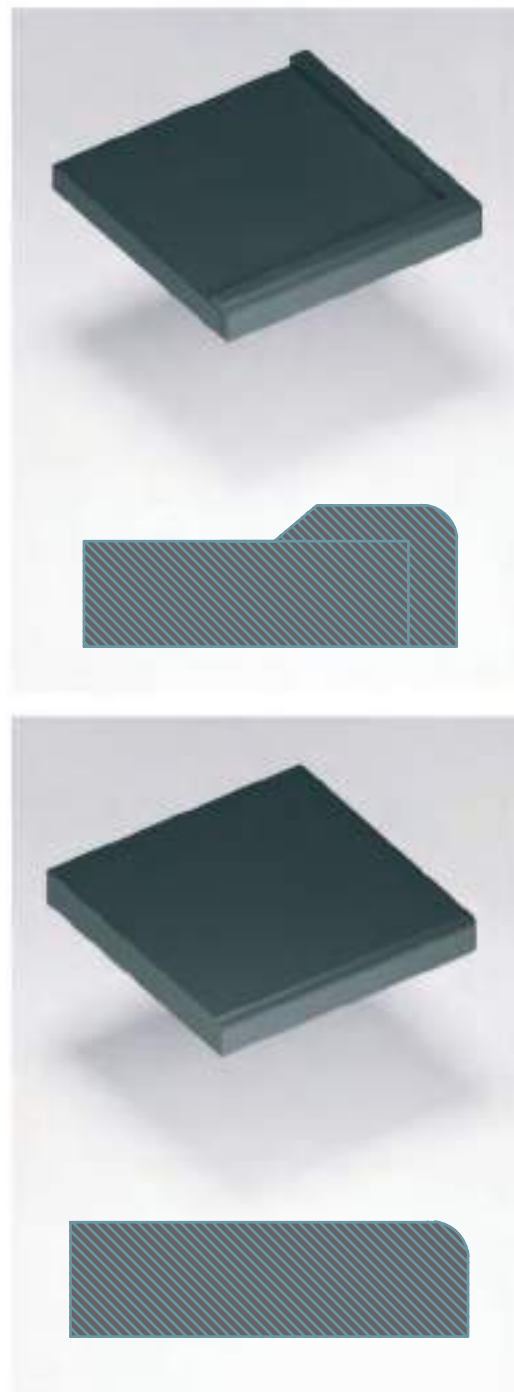

Standard sizes (mm)

Thickness	19
Overall thickness	30

Vitrous enamel steel

Profiled steel worktop, with acid-proof glazing and soft polyurethane core.

The edges of the counter may be flat and slightly rounded or profiled, overlapped anti-drip.

These tops can incorporate polypropylene sinks, but not the same material. This material can stand various holes and technological cutouts.

INTENDED USE:

Recommendations:

- This type of worktop has a very good chemical, thermal and bacteriological resistance.
- Thanks to the non-porous surface of the enamel, it does not change colour when in contact with most pigments.
- Excellent behavior when exposed to abrasion, UV rays and detergents.

Strengths:

- Resistance to abrasion and high temperatures.
- Ideal for microbiological laboratories, hospitals and medical clinics.
- Molded overlapped anti-drip edge – not applied.
- Light specific weight.

Weaknesses:

- There are no sinks in the same material available, only PP sinks can be incorporated.
- There are few standard sizes for countertops.

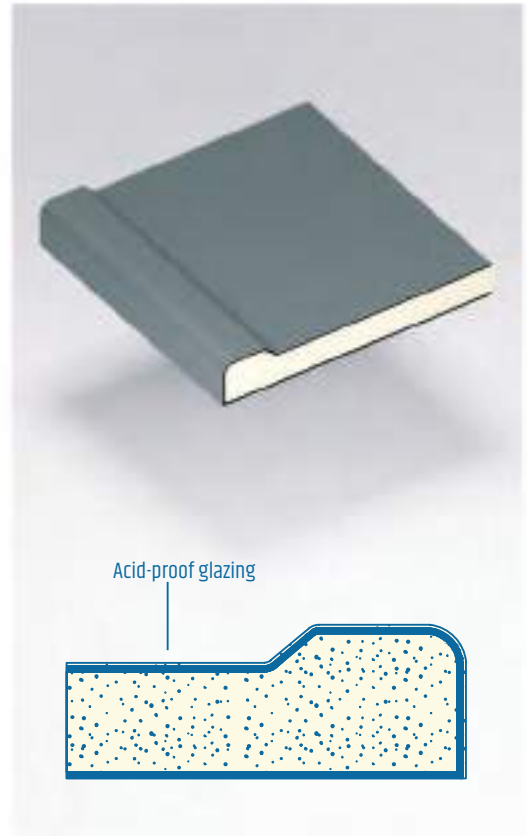

Standard sizes (mm)

Thickness	44
-----------	----

Polypropylene

Thermopressed polypropylene with hollow core. The countertop has anti-drip overlapped edges and can include sinks of various shapes and sizes.

Some countertop units have drainage ducts embossed on the surface, ideal for fitting sanitary units.

INTENDED USE:

Recommendations:

- Ideal in physicochemical laboratories, namely in areas where concentrated inorganic acids are used.
- Recommended for fitting the large sink units and worktops inside the chemical fumehoods.

Strengths:

- The best chemical resistance.
- Sinks of the same material – built-in sinks are made in one piece (injection molded, not attached).
- Many shapes and sizes available.
- Worktops (with or without built-in sinks) always have overlapped anti-drip edge – cast from the same material, not attached.

Weaknesses:

- All parts in PP are white – no other decor is available.
- Poor thermal and abrasion resistance.
- Only standard sizes available, worktops can't stand cutouts on non-standard shaping.

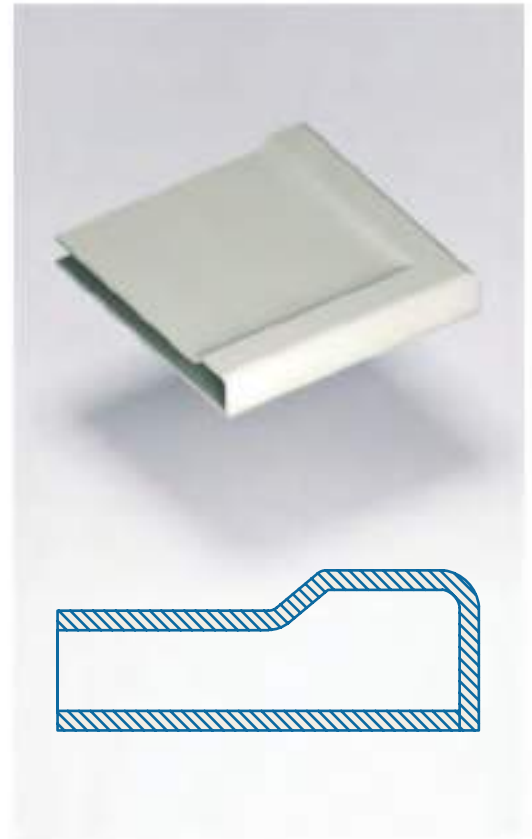

Standard sizes (mm)

Thickness	40
-----------	----

Acid-proof solid-grade HPL laminate

The countertop is made of kraft paper embedded in poliphenolic resins, compacted at high temperatures /high pressure – the resulting material is a compact panel with an acid-proof overlay. The core of the material can be exposed to moisture /water and various detergents, without any visible effect.

Both sides of this material are made of acid-proof melamine.

This type of worktop can withstand various holes and cutouts and can incorporate polypropylene sinks.

The edges of the worktop can be flat (chamfered) or overlapped, anti-drip, made of same material or epoxy resin (optional).

INTENDED USE: Recommendations:

- Solid-grade laminate with acid-proof surface
 - no visible changes when in contact with most concentrated chemical reagents.
- Recommended for any kind of laboratory with non-specific activities – chemical, microbiological, industrial, etc.

*A more simple /basic alternative of this product is also available – solid-grade laminate compact worktop, with melamine overlay on both sides (non-acid-proof). Intended for lab exposed to water, usual cleaning products, but no concentrated corrosive reagents.

Strengths:

- Can be cut and shaped outside standard sizes
 - cutouts and /or irregular shapes.
- Chemical, thermal and abrasion resistance – very good.

Weaknesses:

- There are no sinks made of the same material – sinks provided for this kind of worktop are made of PP, undertop mounted.
- Adhesive overlapped anti-drip edges.

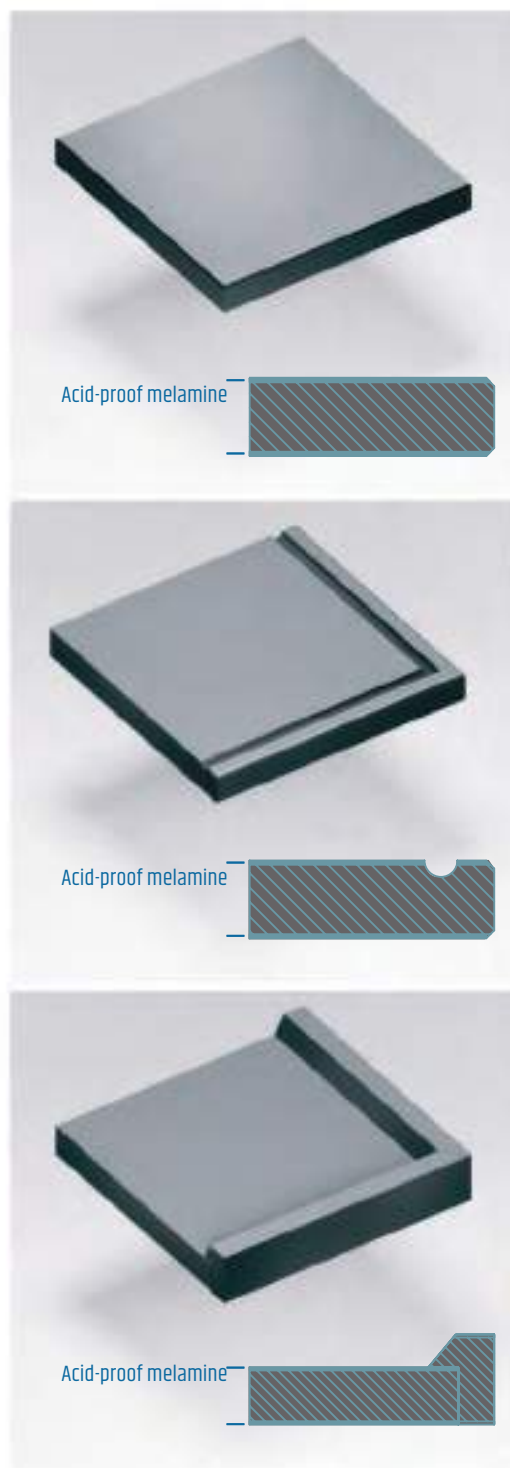

Standard sizes (mm)

Thickness	16,19	Overall thickness	30
-----------	-------	-------------------	----

Black coloured edges

Melamine (optional – acid-proof)

Multilayer countertop made of wood panels with HPL melamine surface and PP edges. On request, the work surface can be acid-proof. The edges of the counter are flat, this kind of worktop does not stand anti-drip overlapped edges. Integrating sinks in this kind of worktops is highly unrecommended.

INTENDED USE: Recommendations:

- Laboratory benches – for regular use.
- Recommended as worktop for writing desks or as countertop /support for laboratory equipment in dry areas, without exposure to wet environments.

Strengths:

- Off-standard shapes and sizes – on request.
- Good chemical resistance – on request.

Weaknesses:

- Not recommended for workareas exposed to water or moisture.
- It is not designed as a worktop for sink units.
- Can't stand overlapped anti-drip edges.

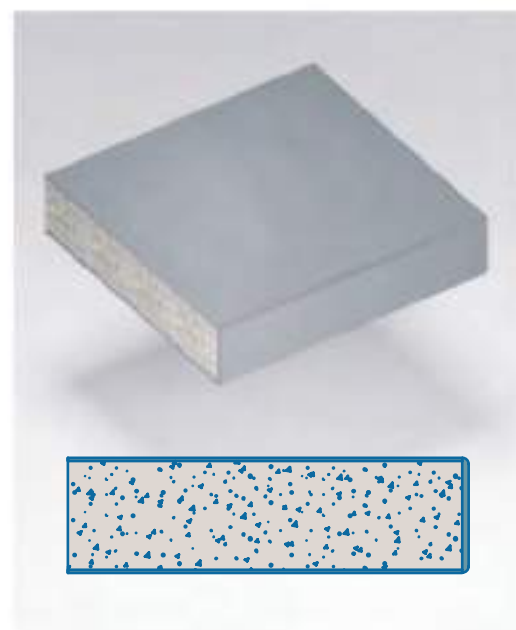

Standard sizes (mm)

Thickness	38
-----------	----

STAINLESS STEEL

Profiled stainless steel worktop. The edges of the worktop are flat and slightly rounded. It does not stand overlapped anti-drip edges or integrated sinks. High wall edge (80 mm) on one side – on demand.

INTENDED USE:

Recommendations:

- For use in microbiology laboratories, in the food industry, in clean rooms.

Strengths:

- Various worktop sizes.
- Good resistance to moisture and detergents.
- Very good thermal resistance.

Weaknesses:

- Low chemical and mechanical resistance.
- No anti-drip edges – optional wall edge on one side.



Standard sizes (mm)

Thickness	32
-----------	----

Quartz engineered stoneware

Engineered stoneware tops – the same material in both mass and surface, with compact, non-porous composition. The edges can be flat (slightly rounded or chamfered) or on demand, with overlapped anti-drip edges made in epoxy.

Stoneware countertops can integrate mineral composite sinks (mounted under the worktop) or PP (mounted on top). Worktops can stand various cutouts, technological holes and non-standard shaping.

INTENDED USE:

Recommendations:

- Because the worktops are casted and have the same material both on the surface and in mass, and the surface is non-porous, this material is suitable for work areas with increased humidity (e.g. washing units) and can stand common disinfectants.
- Because of its high density, this material has a high shock, scratch and abrasion resistance, and is recommended as worktop in specific industrial laboratories or support for standard laboratory equipment or tables.

Strengths:

- Very good mechanical and thermal resistance.
- Non-porous and non-retention: this material is recommended as worktops for bacteriology, virology, microbiology labs, etc.
- Same material both core and surface.

Weaknesses:

- It can only incorporate mineral or PP (applied) sinks.
- Optional anti-drip overlapped edges – made of epoxy resin – adhesive.
- Low chemical resistance.

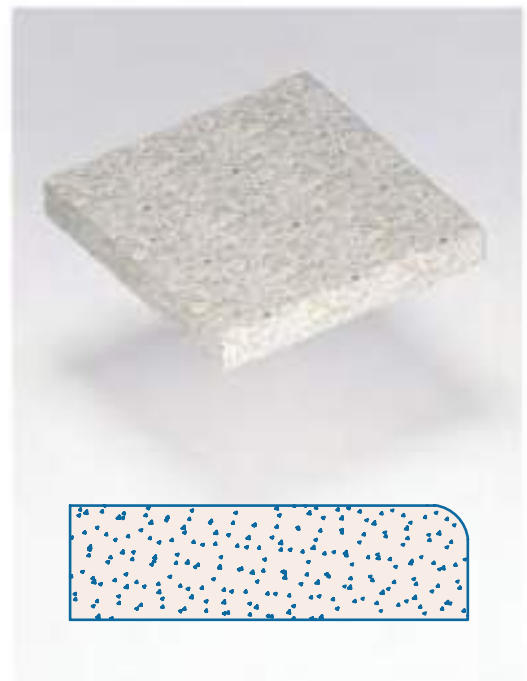
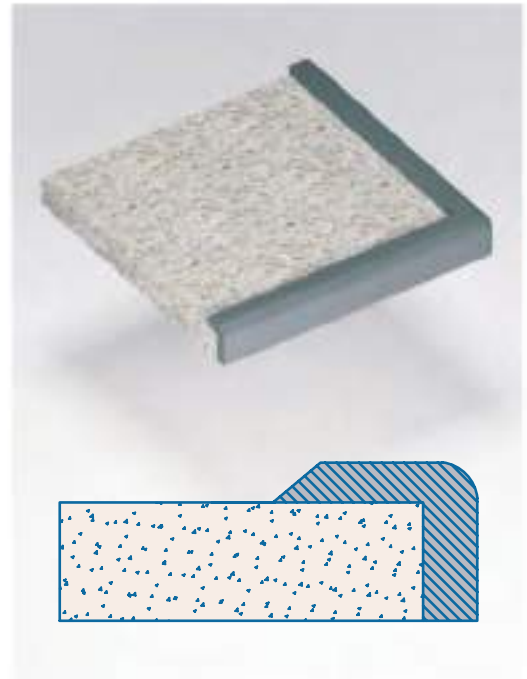

Standard sizes (mm)

Thickness	20	Overall thickness	30
-----------	----	-------------------	----

Mineral composite

Mineral composite worktop – the same material both core and surface, with compact, non-porous composition. The edges of the tops are flat, lightly chamfered.

Countertops made of mineral composite can integrate sinks made of same material, mounted underneath the worktop, with seamless joints. Worktops can stand various cutouts, off-standard shaping or technological holes. The worksurface can be renewed by polishing.

INTENDED USE:

Recommendations:

- Compact, non-porous material
– recommended in hospitals, clinics, and workareas with regular disinfection procedures.

Strengths:

- Large worktops, off-standard shapes and sizes seamless large worktops can be made on request.
- Available sinks made of same material, various shapes and sizes.
- Ideal for work areas exposed to water and moisture.
- Renewable surface by polishing – similar to epoxy resins worktops.

Weaknesses:

- Low shock, scratch and chemical resistance.
- Low-thickness – countertops don't stand heavy loads.

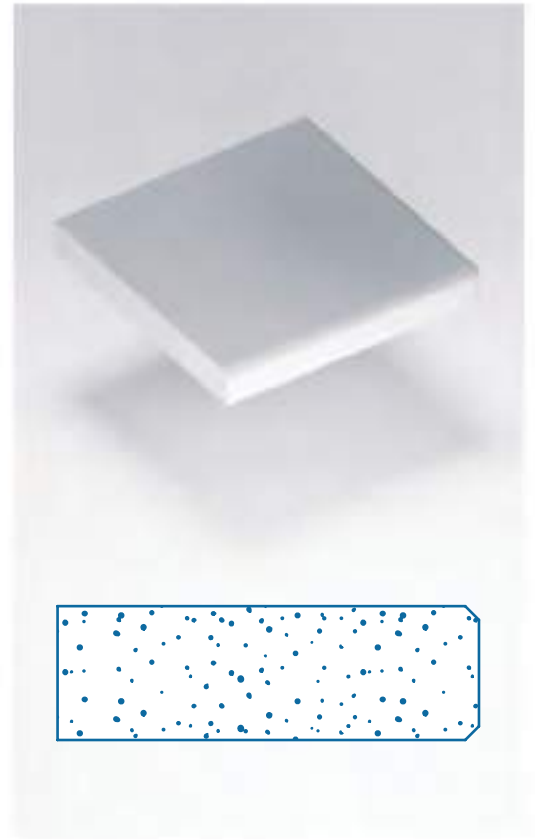

Standard sizes (mm)

Thickness	12
-----------	----

SERVICE UNITS

Integrated self-contained accessories and supplies units.

The laboratory work standards involve strict and clear rules for both electric and for technical or flammable gas supplies layout.

Workbenches are equipped with technological panels, in order to comply with the current standards and the laboratory activity to be carried out in optimal conditions and maximum safety.

Service panels – in all their dimensional versions, and with all the available equipment levels, transform simple laboratory tables into professional and fully functional work stations, the user having in his immediate surrounding all the utilities and supplies required for his work and equipment.



MODULARITY · ERGONOMICS · UTILITIES EQUIPMENT

Service panels for both linear benches against the wall and island /central work compositions:

- **Minimal System** – service unit wall mounted, freestanding or fixed on benches metallic frame, grouping the supplies in an accessible area, hiding unaesthetic and dangerous, supplies connections.
- **Medium System** – shelves and structural metal casing, wall mounted or fixed on workbenches frames, for central layout workstations.
- **Console System** – freestanding construction with multiple configurations for both wall and island workbenches. It consists of a horizontal metal casing, optionally with front skirting panel, with shelves and /or storage units on the upper side fixed on a metal structure.



MINIMAL SYSTEM

Freestanding metal casing, wall mounted or fixed on the benches frame.

Minimal service panel for laboratory workstations, can integrate all service outlets including sockets and multiple connections for gas, water, etc.

For wall workbenches, can be both wall mounted and attached to bench frame. Freestanding and double-sided units available for island workbenches.

Inner and outer corner connections available for continuous panel display, following the laboratory's wall contour.

INTENDED USE: The compact lines of this system make it suitable for laboratory benches that support all kinds of equipments.

Minimal service panel for laboratory workstations mounted on bench frame

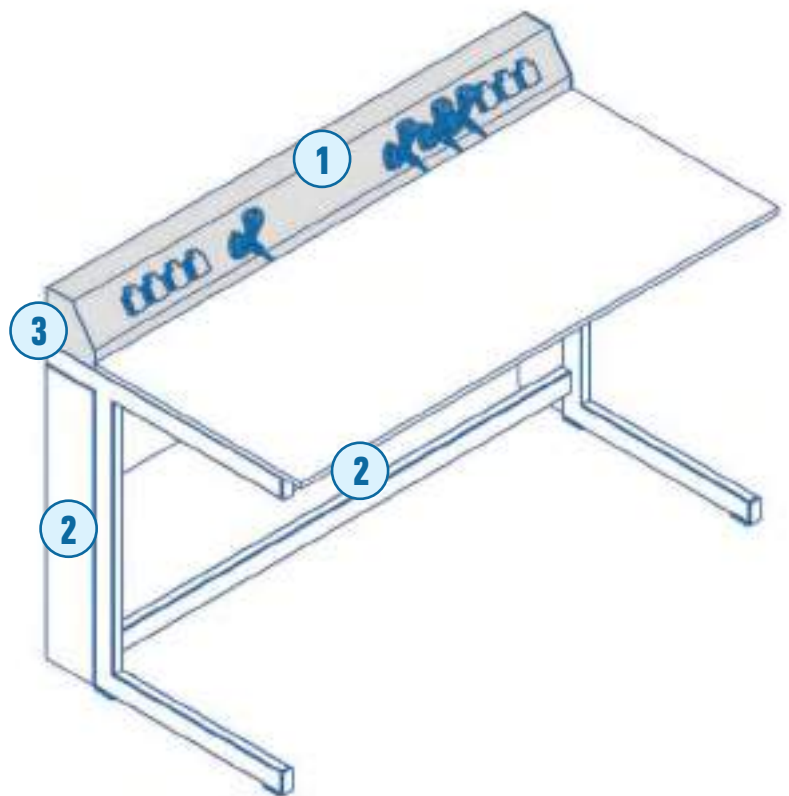

1. Connections to water /electrical /gas supplies are made within the casing. For technical maintenance, connections can be easily reached by removing front panel

2. Connecting elements up to the metal casing on the top are protected with a removable panel, easy to reach at all times

3. The service unit is fixed to the workbenches frames. Total workbench width will also integrate the service panel's width

Standard sizes (mm)

Length	600, 900, 1200, 1500, 1800
Width	100, 150
Height	150, 900, 1050



Wall mounted minimal service panel

Freestanding minimal service panel for single or double workstation

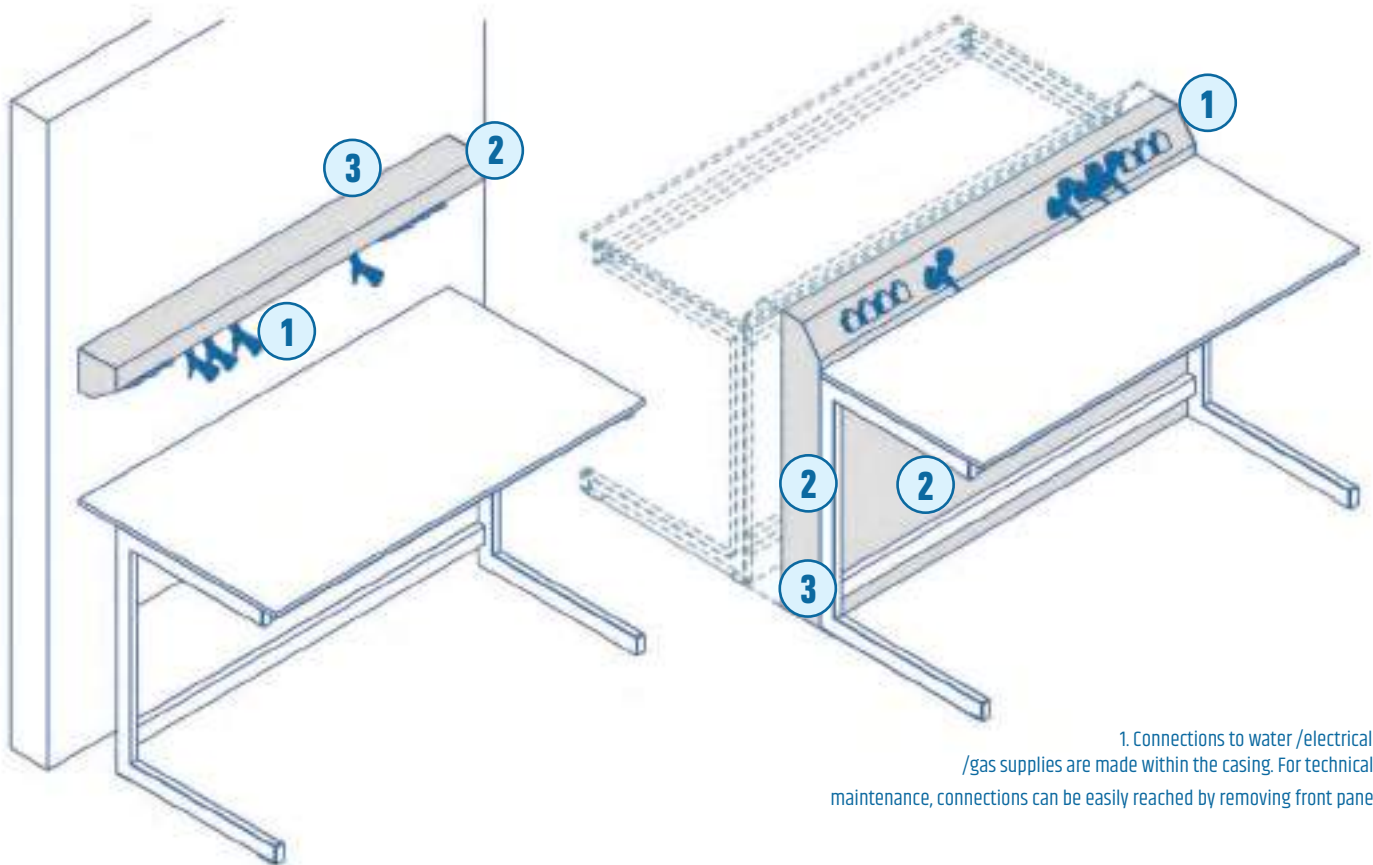

1. Connections to water /electrical /gas supplies are made within the casing. For technical maintenance, connections can be easily reached by removing front panel

2. Connecting elements is possible if all supplies are contained within the casing's body

3. Upper side can be used as storage space for various lab ware

1. Connections to water /electrical /gas supplies are made within the casing. For technical maintenance, connections can be easily reached by removing front panel

2. If necessary, for technical maintenance the panels can be provided with technological capped cutouts

3. Freestanding casing – contains all connections to supplies, floor mounted connections (for island workbench compositions) or wall mounted connections (for linear workstations)



MEDIUM SYSTEM

Medium service panel for laboratory workstations, can integrate all service outlets including sockets and multiple connections for gas, water, etc.

With two fixed shelves for storing various laboratory glassware and equipment.

On worktop level can also integrate one or more small size drain sinks.

INTENDED USE: This solution, having both storage and utility purposes, is intended for most kinds of laboratories, depending on the layout.

Service panel - linear laboratory workbench layout

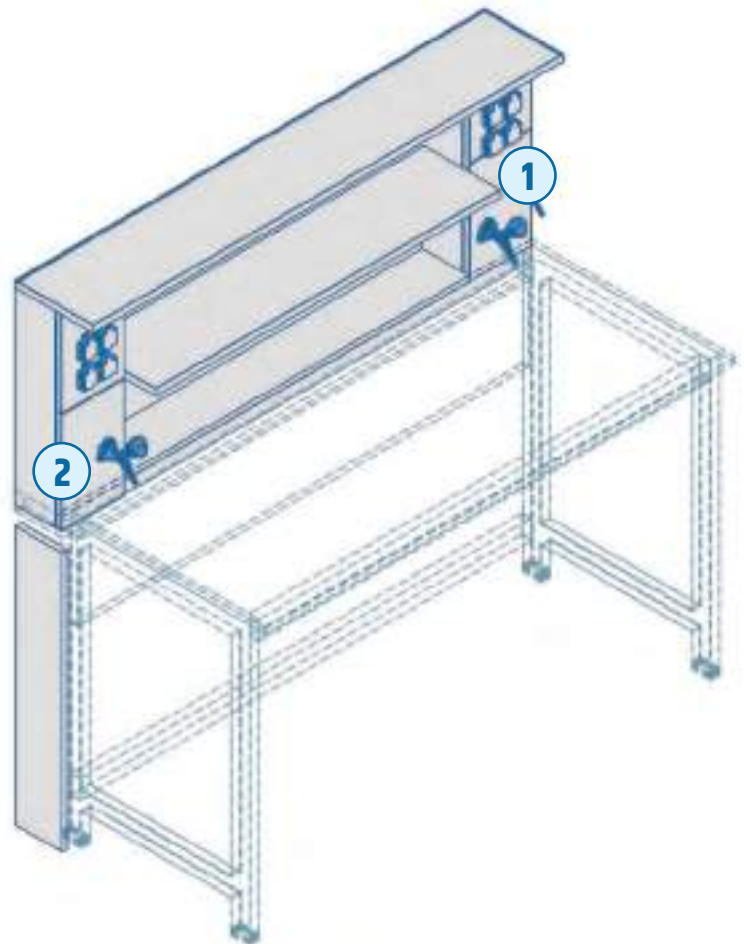

1. Services supply mounted on structural metallic case

2. Connections to water /electrical /gas supplies can be set both under the worktop and up to 600 mm over worktop height.

Standard sizes(mm)

Length	600, 900, 1200, 1500, 1800
Width	100, 150
Shelf width	250
Height	600



Service panel – island laboratory workbench layout

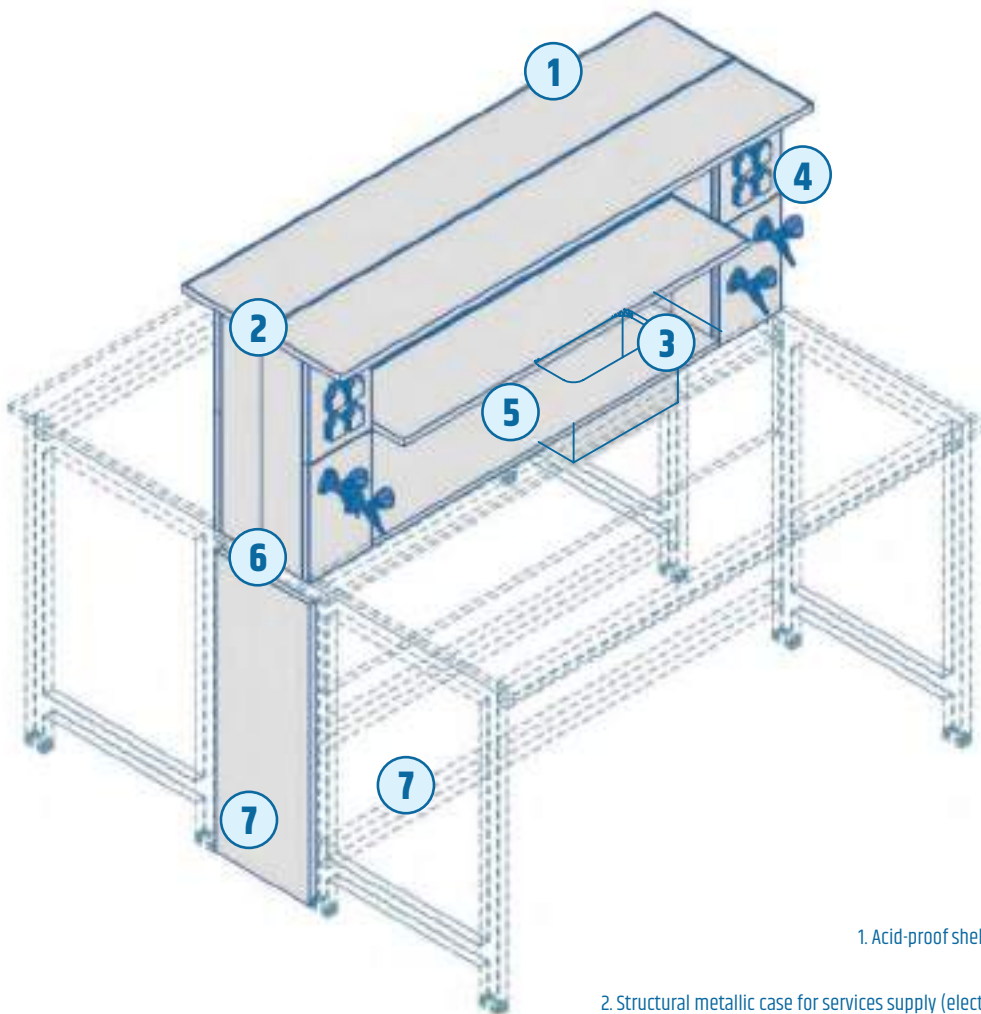

1. Acid-proof shelving for storing laboratory glassware and equipment

2. Structural metallic case for services supply (electric sockets, water, gas, etc) – removable front panels

3. Worktop height drain sink

4. Taps and plugs mounted on easy to remove metallic panels

5. One or more drain sinks can be installed. /

6. For island workstations, two medium service panels are fixed back to back and connected to the benches frames and supplies

7. Connecting elements up to the metal casing on the top are protected with a removable panel, easy to reach at all times

CONSOLES

Complex modular service panel system made of various components: open adjustable shelving, suspended cabinets, detachable vertical panels for non-electrical supplies, electrical supplies body and drain sink units.

INTENDED USE: This solution, having both storage and utility purposes, is intended for most kinds of laboratories, depending on the layout.

1. Shelf for glassware /equipment
2. Power sockets console
3. Functional groove for clamping accessories (eg. pipette holder, tissue holder, etc)
4. Metal structure with leveling feet
5. Removable wall for services utilities (non-electrical supplies)
6. Worktop extension - acid-proof HPL
7. One or more PP sinks for draining liquids
8. Non-electrical connections: for water /technical gases /flammable gasses, etc.
9. Electrical plugs with protection cover

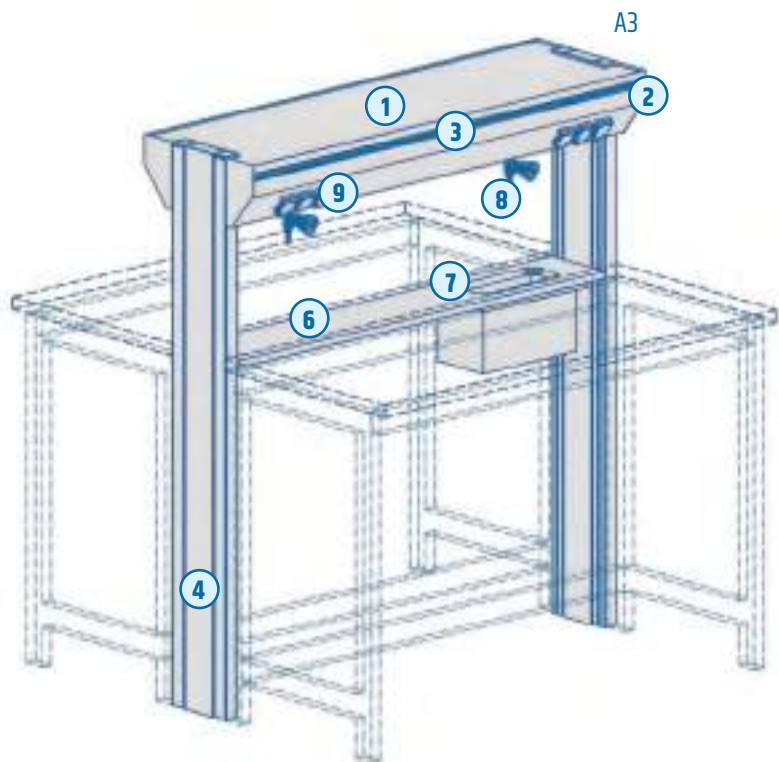

Standard sizes (mm)

Length	600, 900, 1200 1500, 1800
Width	A1 - 150 A2 - 250 A3 - 400
Height	1400

Installing:

- Island workbench console without closing front panels:
This construction is freestanding, fixed to the workbenches frames.
- Maintenance /service access: Top shelf is removable.

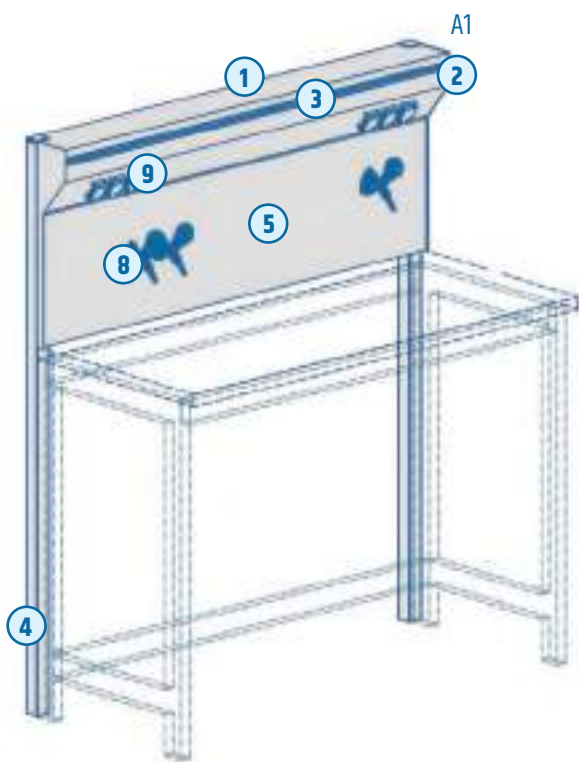

Installing:

- Wall mounted console with front closing panel: The console's metal structure is installed by fixing it to the workbenches frame.
- Maintenance / service access: All connections fixed behind the panel can be easily accessed - detachable panel.

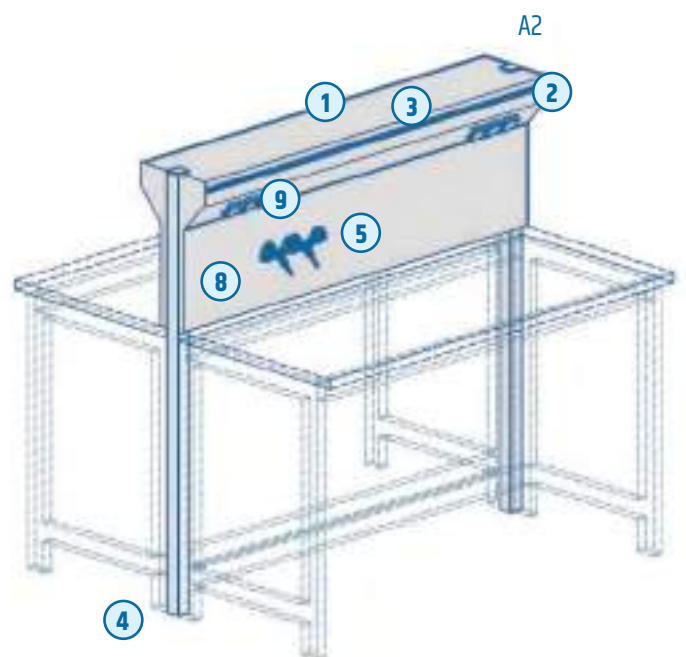

Installing:

- Island layout console with front cover panels: The console's body is installed by fixing its metal structures to the adjoining workbenches frames.
- Service and access to connections: All connections fixed within the panel's area can be easily accessed - detachable panel.



CONSOLES

SHELF UNIT CONSOLE

1. Shelf for glassware /equipment
2. Power sockets console
3. Functional groove for clamping accessories (eg. pipette holder, tissue holder, etc.)
4. Metal structure with leveling feet
5. Removable wall for services utilities (non-electrical supplies)
6. Worktop extension - acid-proof HPL
7. One or more PP sinks for draining liquids
8. Non-electrical connections taps for water /technical gases /flammable gasses, etc.
9. Electrical plugs with protection cover
10. One or two metal shelves with acid-proof storage surface and adjustable height mechanism. Optional feature - LED lamp (height not adjustable)
11. Top shelf with acid-proof storage surface

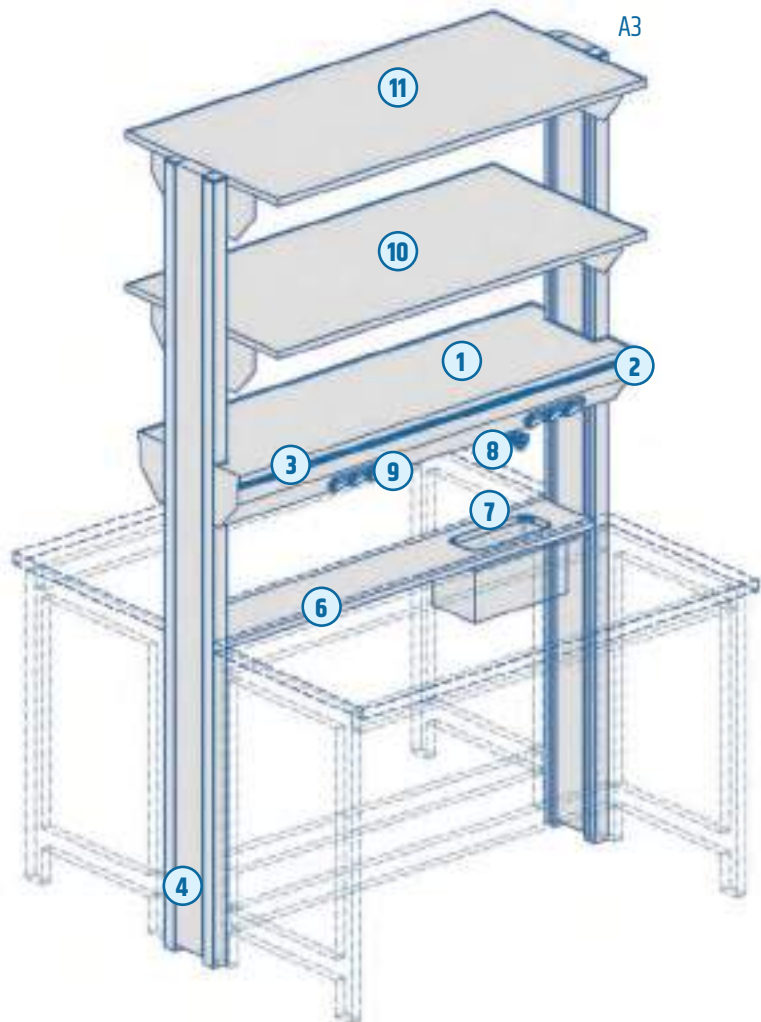

Standard sizes (mm)

Length	600, 900, 1200 1500, 1800
Width	A1 - 250 A2 - 425 A3 - 600
Height	2200, 2400

Installing:

- **Island workbench console without closing front panels:** This construction is freestanding, fixed to the workbenches frames.
- **Maintenance /service access:** The metal casing's top is removable.
- **Configuration:** One or more height adjustable shelves and one fixed top shelf; with one or more sink units integrated. Optional LED light can be installed on first shelf (fixed).

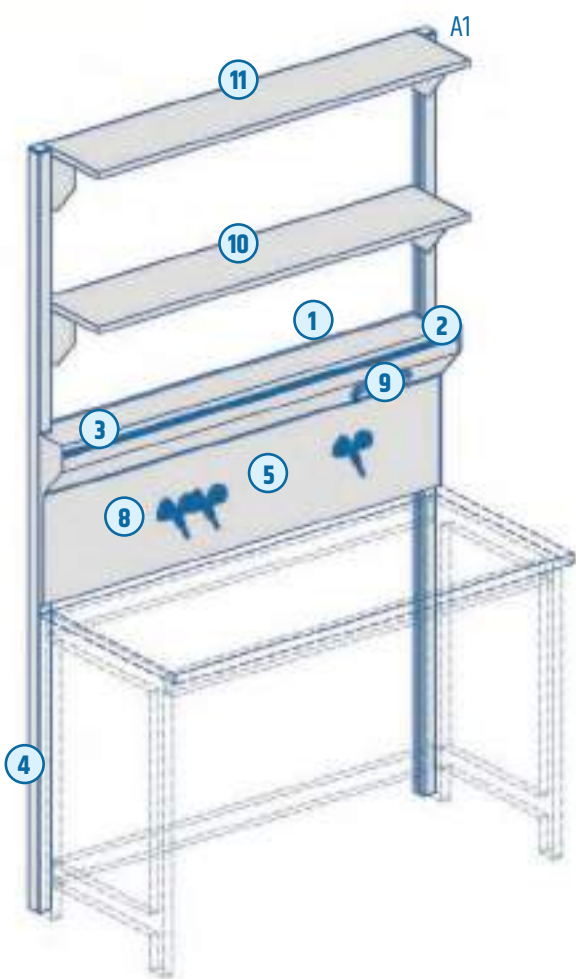

Installing:

- **Wall mounted console with front closing panel:** Fixed to the workbenches frames or to the wall.
- **Maintenance /service access:** Removable shelves and front panel.
- **Configuration:** One or more height adjustable shelves and one fixed top shelf. Optional: LED light can be installed on first shelf (fixed).

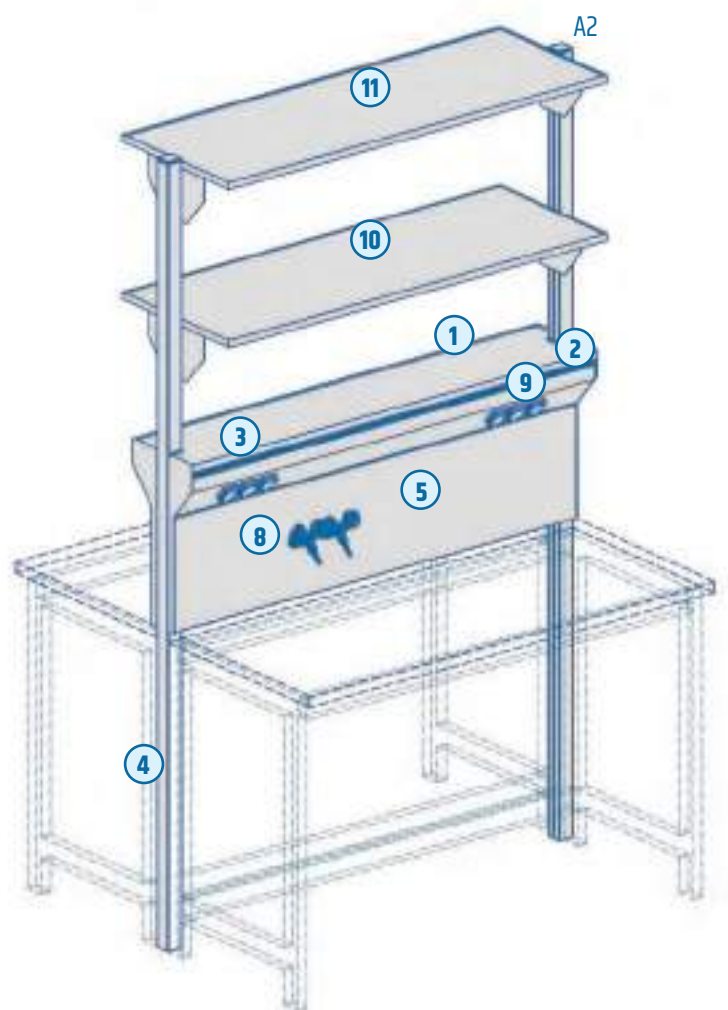

Installing:

- **Island workstation console:** Mounted on benches frames, with front closing panels.
- **Maintenance /service access:** Removable shelves and front panels
- **Configuration:** One or more height adjustable shelves and one fixed top shelf. Optional: LED light can be installed on first shelf (fixed).

CONSOLES

CONSOLE WITH SUSPENDED CABINETS

1. Shelf for glassware /equipment
2. Power sockets console
3. Functional groove for clamping accessories (eg. pipette holder, tissue holder, etc.)
4. Metal structure with leveling feet
5. Removable wall for services utilities (non-electrical supplies)
6. Worktop extension - acid-proof HPL
7. One or more PP sinks for draining liquids
8. Non-electrical connections: taps for water /technical gases /flammable gasses, etc.
9. Electrical plugs with protection cover
10. Suspended storage unit with two or more compartments, 450 or 700 mm in height. Optional feature - LED lamp underneath

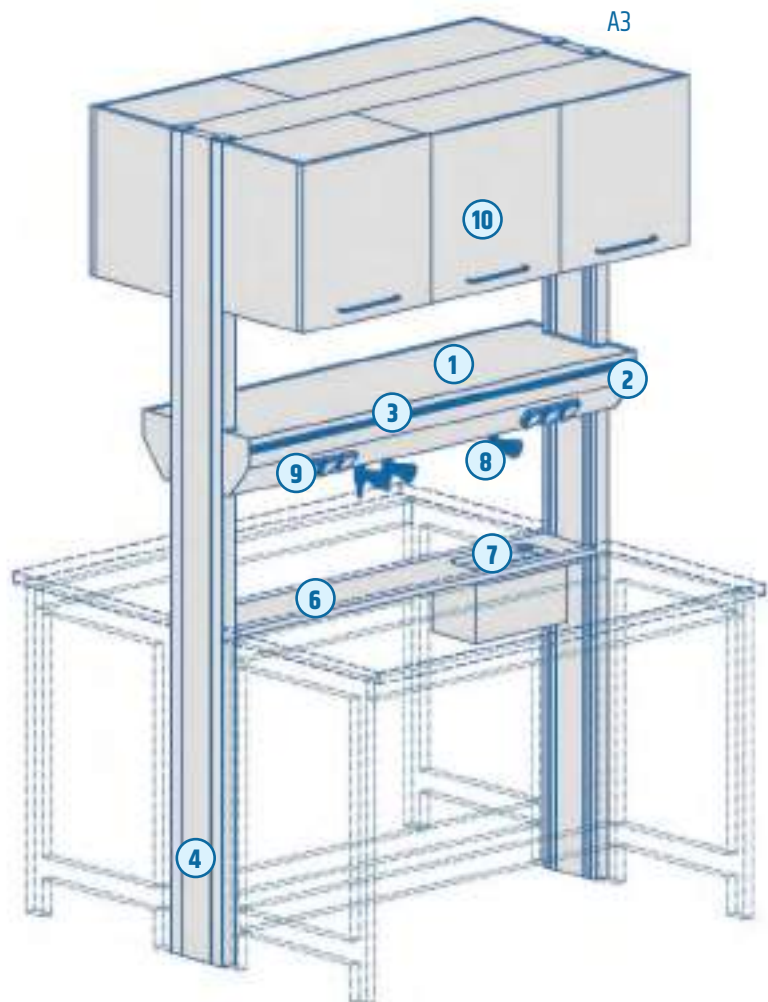

Standard sizes (mm)

Length	600, 900, 1200 1500, 1800
Width	A1 - 350 A2 - 710 A3 - 810
Height	2200, 2400

Installing:

- Island workbench console without closing front panels:
This construction is freestanding, fixed to the workbenches frames.
- Maintenance/service access: Top shelf is removable.
- Configuration: Optional: LED light can be installed on suspended cabinet (fixed).

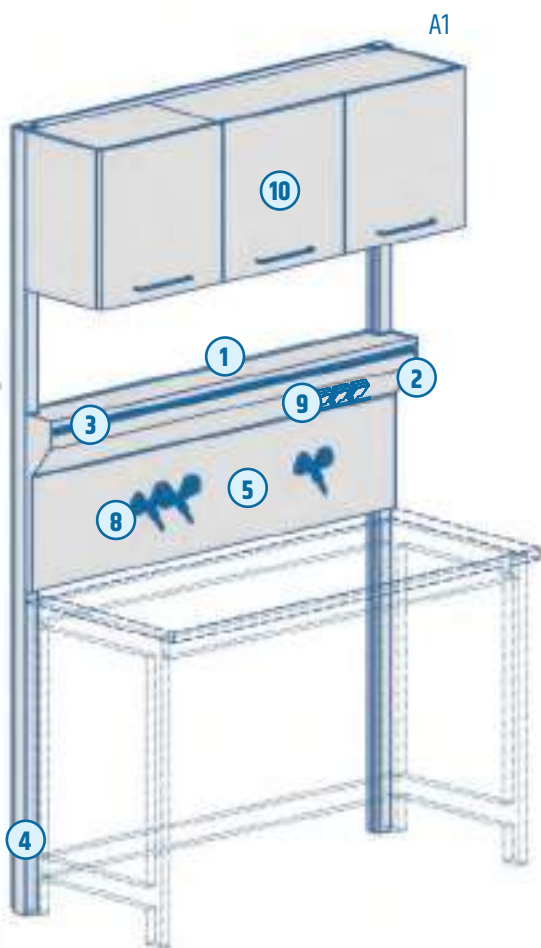

Installing:

- Wall mounted console with front closing panel: Fixed to the workbenches frames or to the wall.
- Maintenance /service access: Removable shelf and front panel.
- Configuration: Optional: LED light can be installed on suspended cabinet (fixed).

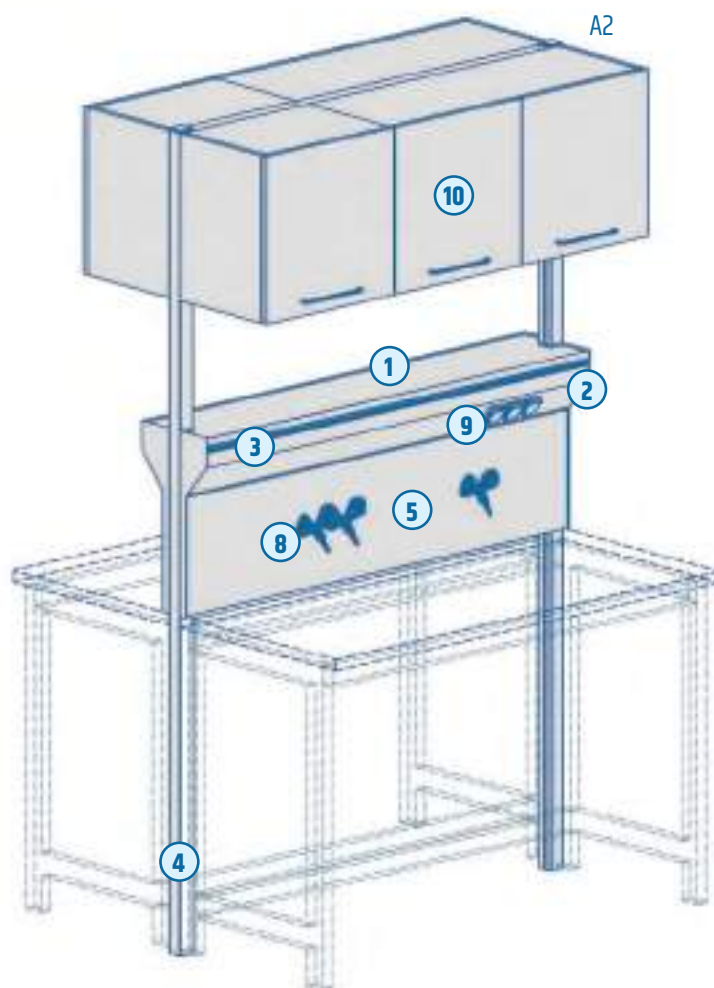

Installing:

- Island workstation console: Mounted on benches frames, with front closing panels.
- Maintenance /service access: Removable shelf and front panels.
- Configuration: Optional: LED light can be installed on suspended cabinet (fixed).

ACCESSORIES FOR SERVICE PANELS

Wall or bench-mounted, the laboratory taps are made of highly resistant and non-corrosive materials, being also in accordance with the current EU norms.

WATER TAPS

Water taps can be supplied with oil bath head valve sealing in EPDM or with 1/4" turn ceramics head valve.

Maximum working pressure 10 Bars.

Nozzle with possibility of disassembly in compliance with DIN 12898 regulation.

Handles in compliance with EN 13792:2000 norm, manufactured in acid-resistant PP.

Threads in compliance with ISO 228/4 regulation, B tolerance class.

Taps are built following the DIN 12918 norm.



11003.1MDS
45° handle and nozzle water tap



11011.2MDS
45° handle and nozzle water tap



11001.1MDS
Water 90° tap



11012.2MDS
Water 90° tap



11000.1MDS
Water straight tap



11010.2MDS
Water straight tap



11014.2MDS
Wall mounted u-tap with nozzle 90°



11023.2MDS
Vertical "Y" tap

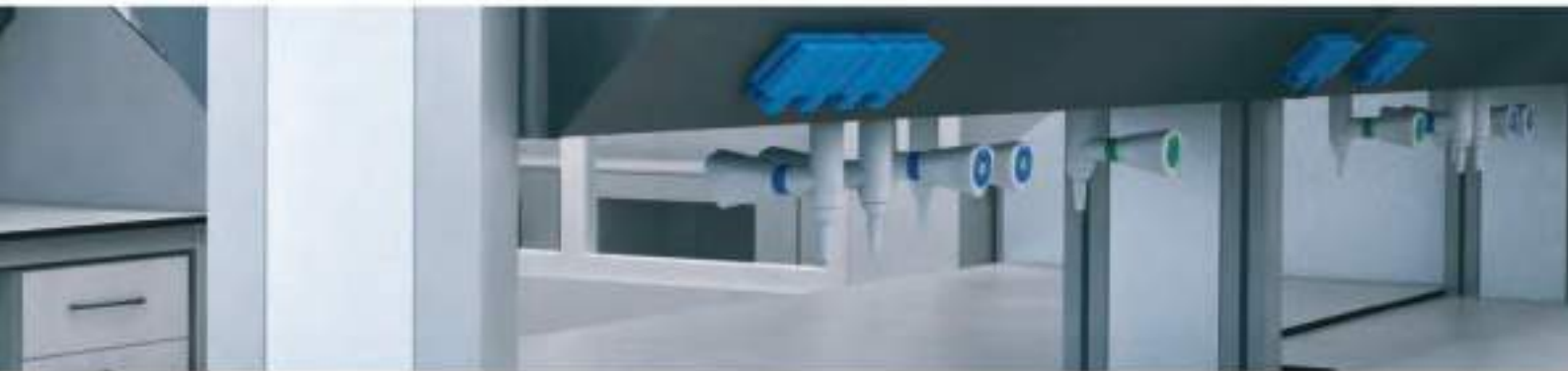

PURE WATER TAPS

Pure water taps are made in RAL 7032 colour, and allow that the water erogated goes in touch only PP and never with metals or other contaminating materials.

The open and close system is a PP ceramic headwork with 90° rotation and can work up to 6 Bars pressure.

All the models made in PP are supplied with a G 1/2" male threaded leg, and a female G 1/4" thread that allow to screw inside a connector in PP for tube diameter external 8 mm and internal 6 mm.

All the taps are also supplied with a PP rosetta, with laser printed the chemical abbreviation of the water following the EN 13792 norm, as also the textual indication. All the taps are supplied with removable nozzle G 1/2".



11010.2MDSPP
Straight pure water PP tap

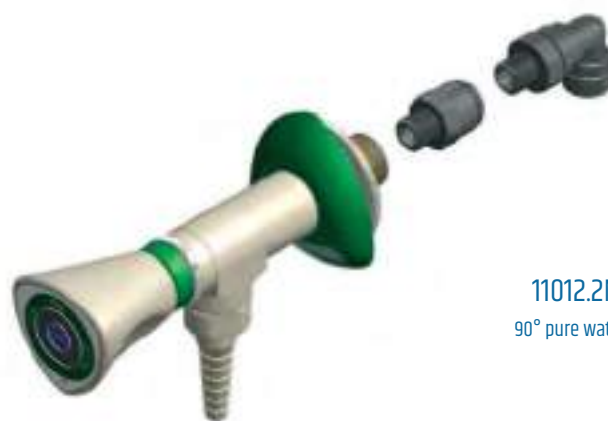

11012.2MDSPP
90° pure water PP tap



11031.2MDSPP
Wall pure water PP tap with swivelling spout

ACCESSORIES FOR SERVICE UNITS

TAPS FOR TECHNICAL GASES

The taps for technical gases are supplied with refined adjustment head valve, with sealing in PTFE. Fixed nozzle in compliance with the DIN 12898 regulation.

Handles in compliance with EN 13792:2000 regulation and manufactured in acid-resistant PP.

Threads in compliance with ISO 228/1 regulation, B tolerance class.

Taps are built following the DIN 12918 norm. The taps for oxygen and hydrogen are equipped with an headwork lubricated with specific and omologated grease.

Maximum working pressure - 10 Bars.

Taps finished with acid-resistant epoxy powder painting.



13050.2MDS

Straight tap



13051.2MDS

Wall mounted tap with 60° nozzle



13052.2MDS

Wall mounted tap with 45° handle and nozzle



13062.2MDS

90° "Y" technical gases tap



13002.1MDS

Wall handle and nozzle 45° tap



13012.2MDS

Bench 90° stand out



13000.1MDS

tap



13064.2MDS Straight

Vertical tap



13010.2MDS

Single stand out



13011.2MDS

Bench 180° stand out

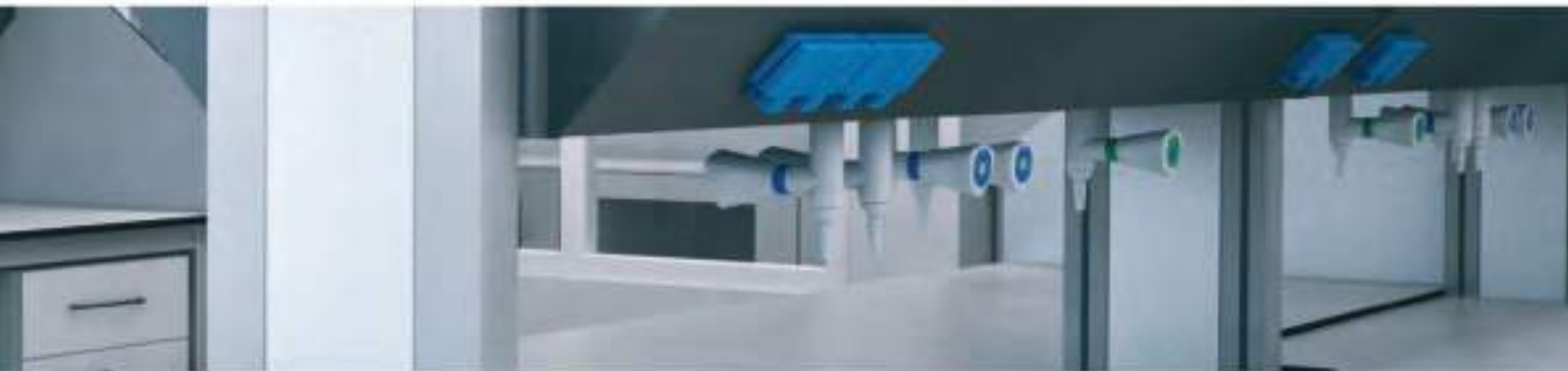

TAPS FOR FLAMMABLE GASES

Taps for combustible gases are supplied with ceramic safety spring lock head valve. Fixed nozzle in compliance with the DIN 12898 regulation.

Handles in compliance with EN 13792:2000 regulation and manufactured in acid-resistant PP.

Threads in compliance with ISO228/1 regulation, B tolerance class.

Taps are built following the DIN 12918 norm.

The taps for combustible gases are tested for maximum working pressure of 0,2 Bars, manufactured under DIN 12918, and are all DVGW approved.

Taps finished with acid-resistant epoxy powder painting.



12051.2MDS

Wall mounted tap with 60° nozzle



12011.2MDS

Bench 180° standout



12050.2MDS

Straight tap



12012.2MDS

Bench 90° standout



12052.2MDS

Wall mounted tap with 45° handle and nozzle



12060.2MDS

Straight "Y" burning gases tap



12010.2MDS

Single standout



12062.2MDS

90° "Y" burning gases tap



12053.2MDS

90° burning gases tap



12064.2MDS

Vertical tap

ACCESSORIES FOR SERVICE UNITS

ELECTRIC PLUGS

Single-phase electric plugs, IP44, 230 V /16 A, complete with plastic cover.

INTENDED USE:

Plugs for general use.



HOLDERS FOR GLASSWARE AND ACCESSORIES

Metallic holder, made of epoxy powder-coated steel sheet. It can be mounted on the console's upper rail.

1. Pipette holder: Made of epoxy powder-coated steel sheet or stainless steel sheet for laboratory pipettes or tubes.

2. Documents tray: Metallic holder/tray for papers /documents (A4 format), horizontal or inclined.

3. Glove box holder: Metallic holder for a standard laboratory glove box, with cutout on frontal side, for easy access.

4. Tissue /napkin box holder: Metallic holder for a standard laboratory tissue box, with cutout on frontal side, for easy access.

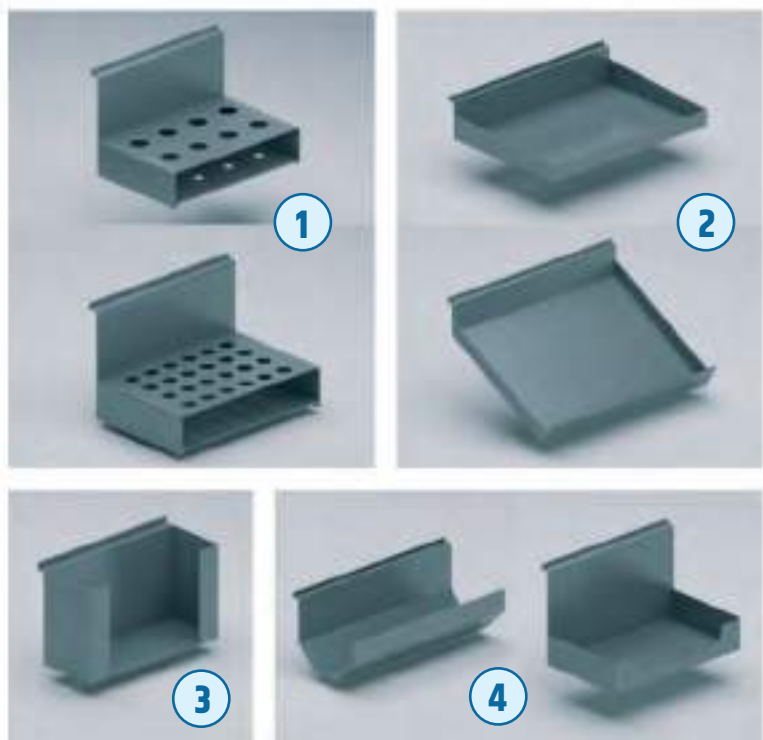



STORAGE UNITS

Modular cabinets and shelf units, available in various configurations for laboratory supplies and documents.

MODULARITY · ERGONOMICS
STORAGE · SPACE EFFICIENCY

The storage units in a laboratory must be ergonomically placed, so that they properly sustain the activity. In this way, our laboratory storage units collection includes:

- **Under bench storage units, fixed or mobile** (on rubber castors), in various dimensions, with doors or drawers.
- **Suspended storage units**, wall mounted or fixed on the service panels metallic frame, with or without doors.
- **Freestanding units or on plinth**. They come in various configurations and dimensions, for documents and supplies storage.



1. Under bench cabinets - on castors. 2. Under bench cabinets - fixed.
 3. Under bench cabinets - fixed, freestanding, on plinth. 4. Suspended cabinet - mounted on consoles metal frame /wall mounted /top cabinet - stacked on top of freestanding units. 5. Freestanding on plinth - H 900, H 1200, H 2000.

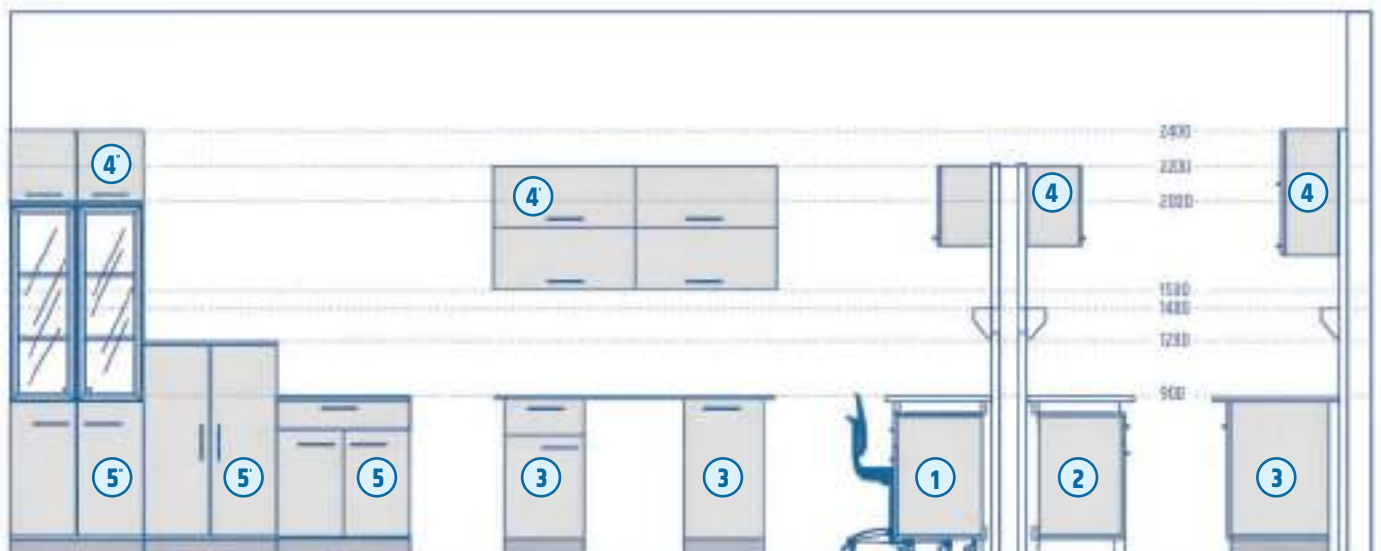

UNDER BENCH UNITS

Storage units, installed under the laboratory worktop, fixed, on plinth, or mobile (on rubber castors), equipped with doors or drawers.

Construction types:

- **The inner case:** made of wooden melamine panels, with PP edges.
Optional: top panel can also be made in solid-grade HPL laminate, in order to use them as an worktop extension.
- **Doors:** laminated HPL-plated boards, complete with 270° - opening hinges.
Optional: solid-grade HPL laminate panel (12 mm thick).
- **Drawers:** completely metallic interiors, total extraction sliders with soft-closing system.
Optional: 2 keys metallic lock.

INTENDED USE: For storage of supplies and /or lab equipment of immediate use - under the top.

Under bench cabinets on castors

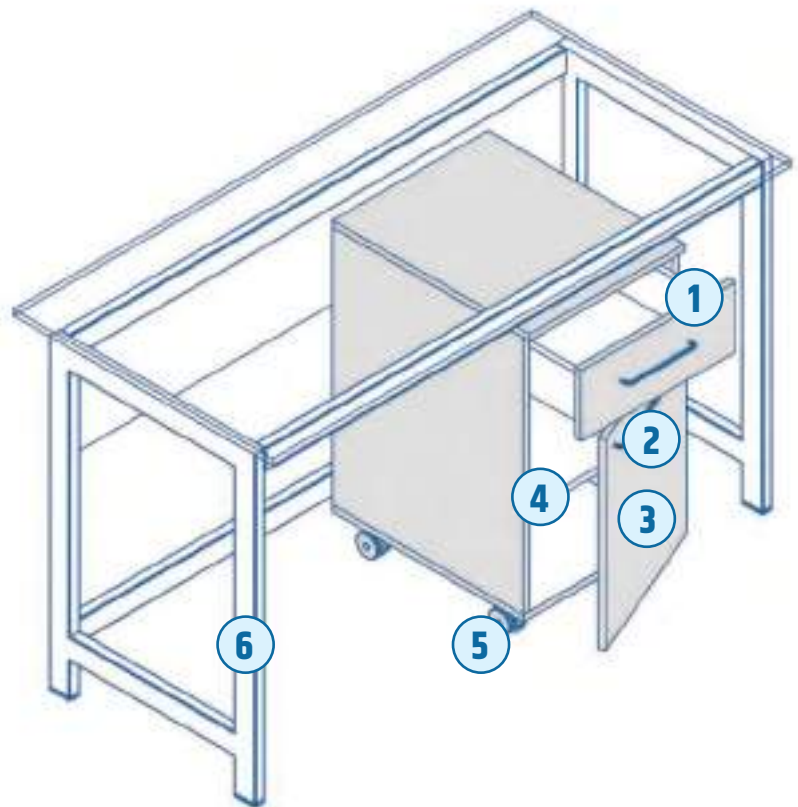

1. Drawer with total-extraction sliders with soft-closing system

2. Metallic handle

3. Doors with 270° opening hinges

4. Shelf with adjustable height system

5. Castors in hard rubber with blocking system

6. "C" or "H" frame workbench



Fixed under bench cabinets

Fixed under bench cabinets on plinth

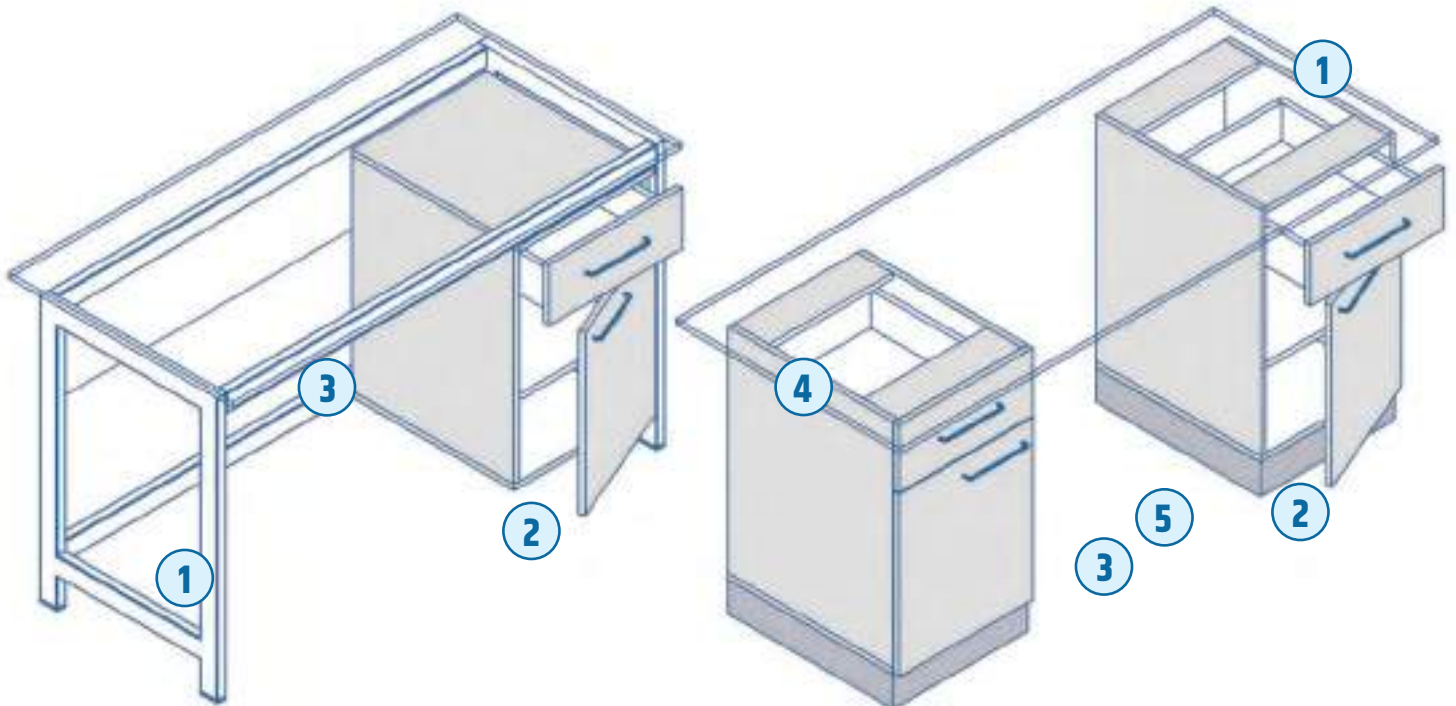

1. Structural cabinet on plinth – holds worktop in place

2. Plinth – floor sealed with pasting

3. Depending on the size of the worktop, it requires a minimum of two structural cabinets to support the top so that there's no more than 750 mm between cabinets and 300 mm on sides

1. "C" or "H" workbench

2. Room for cleaning access

3. Fixing cabinet on workbenches joists

4. Max. 300 mm

5. Max. 750 mm



UNDER BENCH UNITS

Configuration

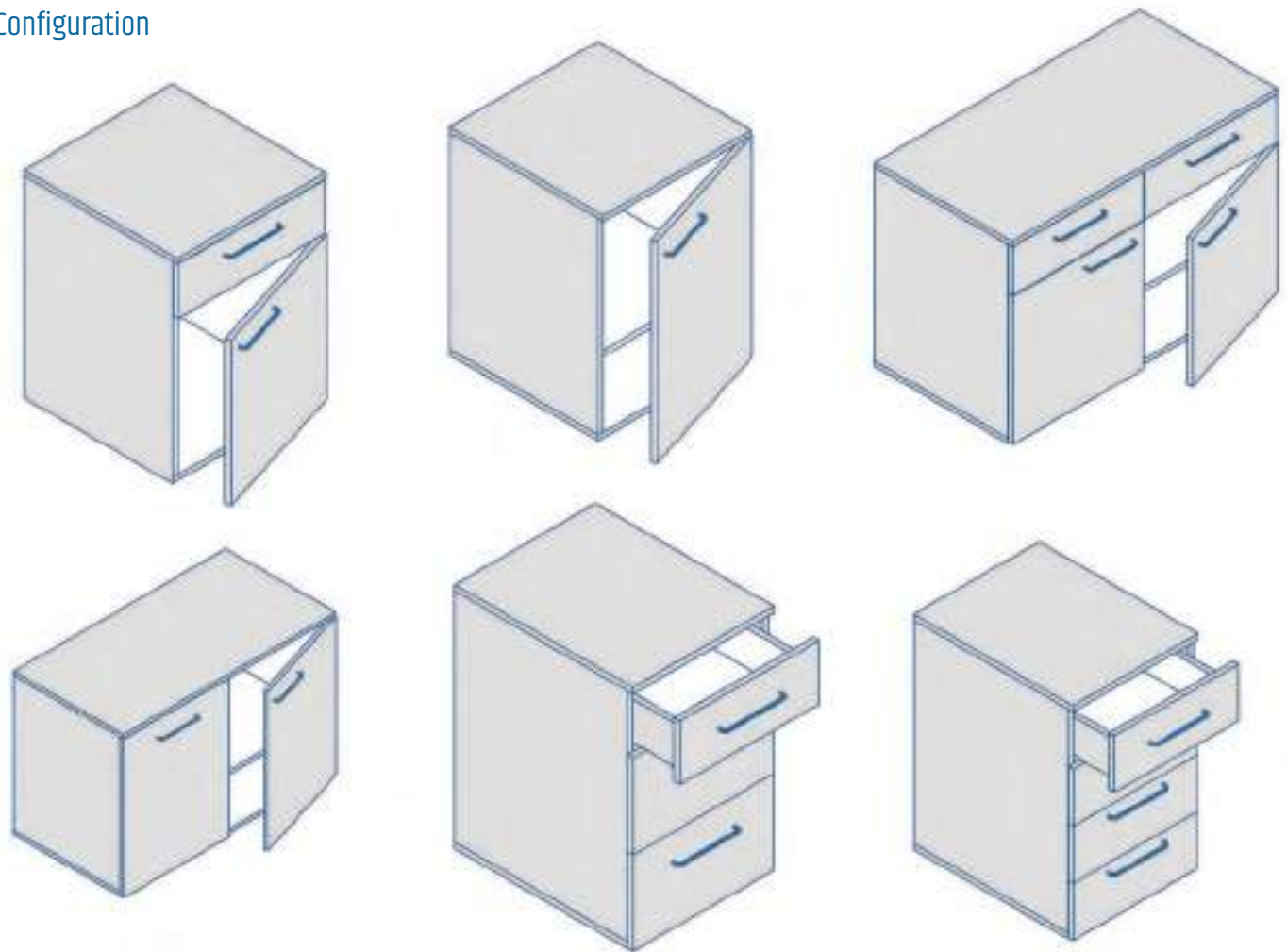

Standard sizes

Length	1 segment 400, 450, 500, 550, 600	2 segments 650, 700, 750, 800, 850, 900, 950, 1000, 1050, 1100, 1150, 1200
Width	420, 510	
Height	665, 815	

SUSPENDED CABINETS

Suspended storage units can be installed directly on the wall or fixed on the service panels.

Construction types:

- **The case:** made of wooden melamine panels, with PP edges.
- **Doors:** laminated HPL-plated panels, with 270° opening hinges.
- **Glass doors:** with metal frame With 110° opening hinges.

INTENDED USE:

For storage of documents, supplies and /or lab equipment.

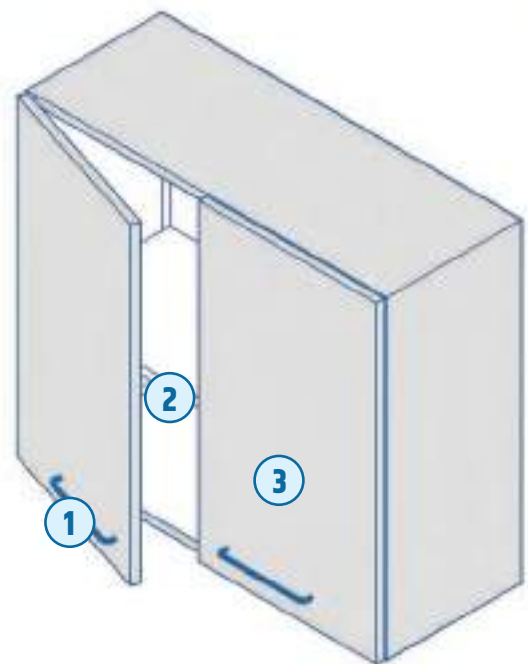

1. Metallic handle
2. Shelf with adjustable height system
3. Doors up to 270° hinges
*Glass doors hinges 110° opening

Configuration

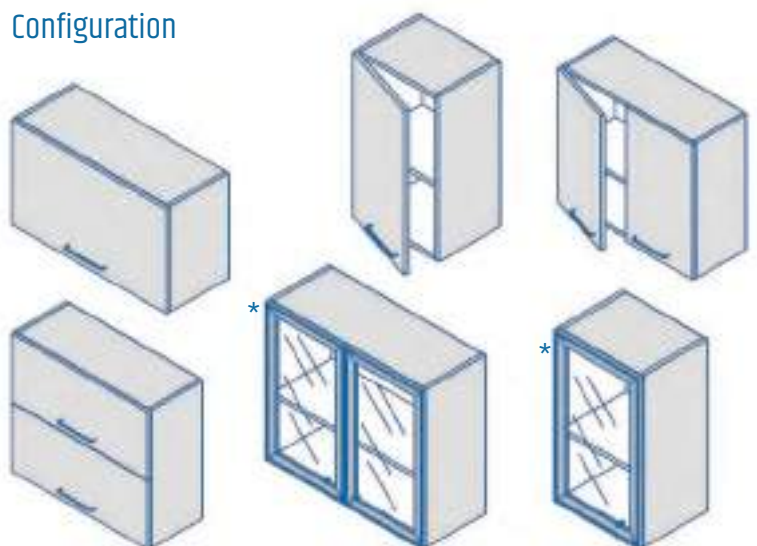

Standard sizes

Length	1 segment 400, 450, 500, 550, 600
	2 segments 650, 700, 750, 800, 850, 900, 950, 1000, 1050, 1100, 1150, 1200
Width	300, 400
Height	300, 350, 400, 700, 800

FREESTANDING CABINETS ON PLINTH

Freestanding storage units, floor mounted, equipped with metallic lower plinth, and complete with levelling system.

They can be ordered with /without doors (laminated or glass), with or without drawers, with inner shelves or holders for clothes /work apparel and /or additional storage space for cleaning products /materials.

INTENDED USE: For storing papers /documents (archives), lab supplies accessories or clean /sterile lab glassware.

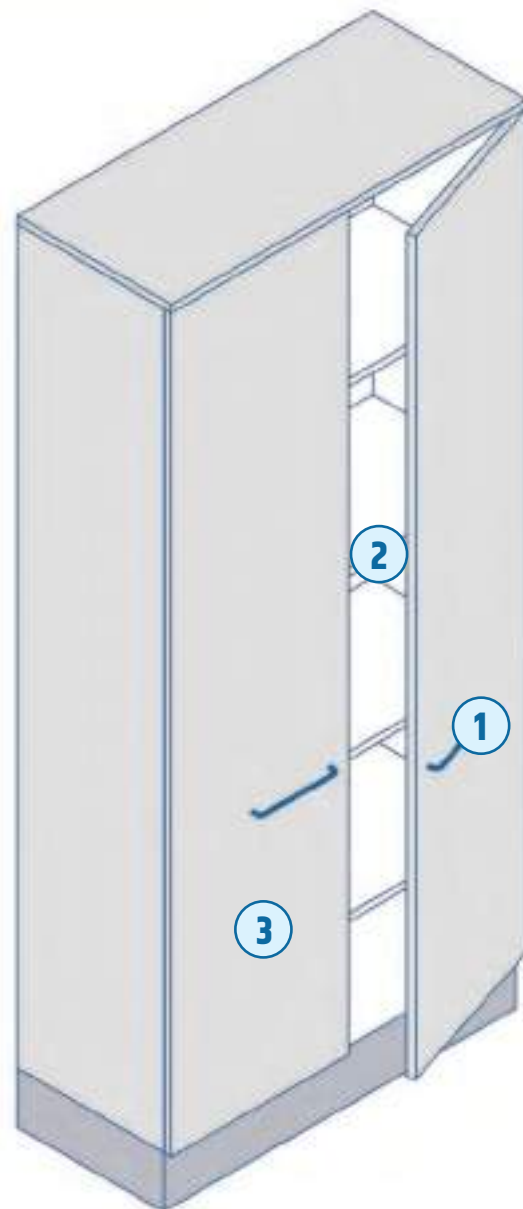

1. Metallic handle

2. Shelf with height adjustable system

3. Door with 270° hinges

*Glass doors hinges 110° opening

Standard sizes

Length	1 segment 400, 450, 500, 550, 600
	2 segments 650, 700, 750, 800, 850, 900, 950, 1000, 1050, 1100, 1150, 1200
Width	300, 400, 500, 600
Height	900, 1200, 2000



Configuration

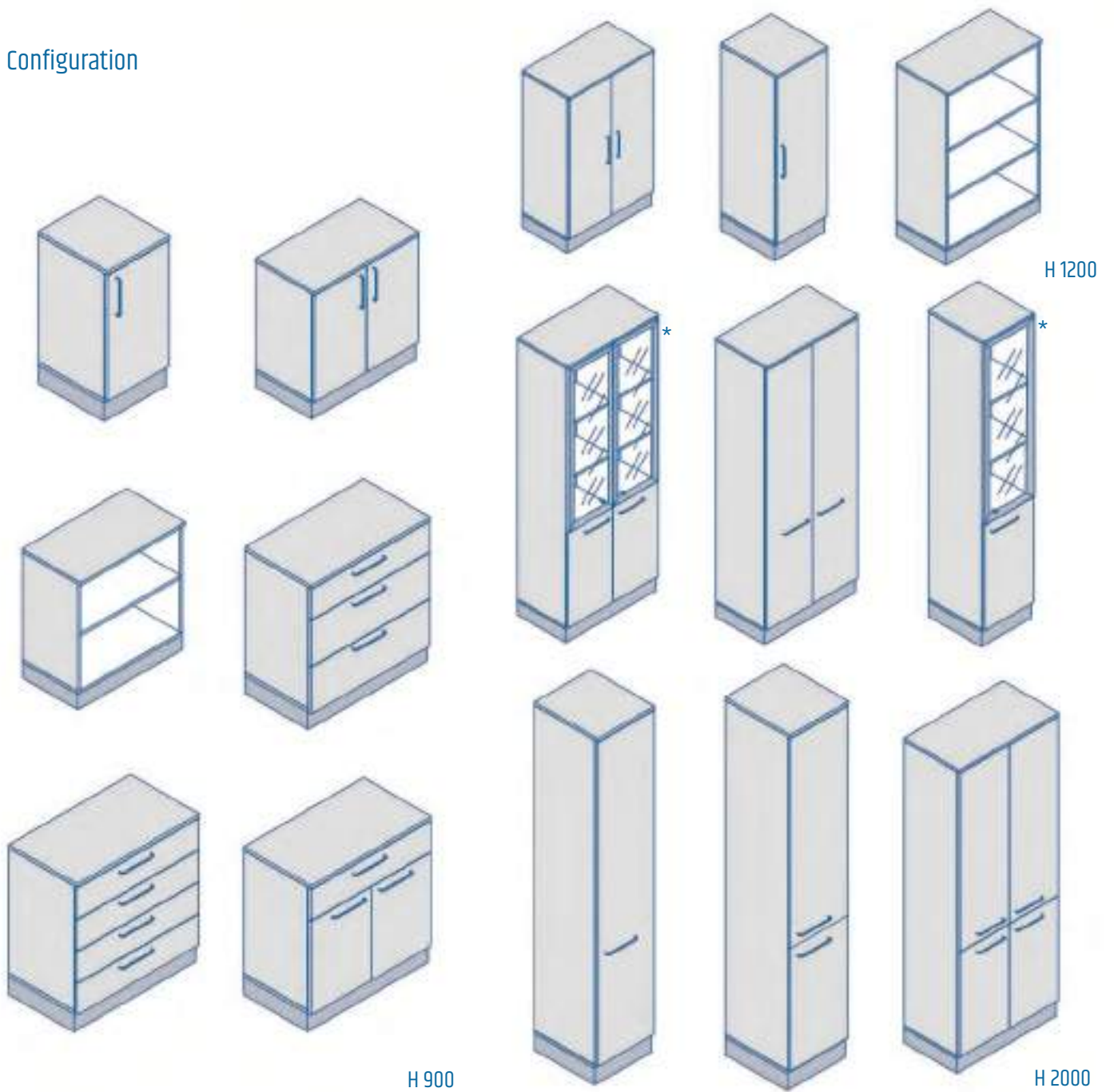

ACCESSORIES FOR STORAGE UNITS

VERTICAL DRAWER /METALLIC SHELF EXTRACTABLE COLUMN

Vertical drawer with metal shelving. Depending on cabinet's height, the drawer can be equipped with up to 6 shelves.

Dimensions: On request.

Restrictions:

Minimum length: 300, 400 mm

Maximum height: 1600-2000 mm

Minimum width: 500 mm



SPECIAL OPTIONAL SHELF

Acid-proof tray made in PP, on full-extension gliders.

The tray can slide entirely outside the cabinet.

PP tray is removable and easy to wash.

Dimensions: On request.

Minimum cabinet width: 300 mm

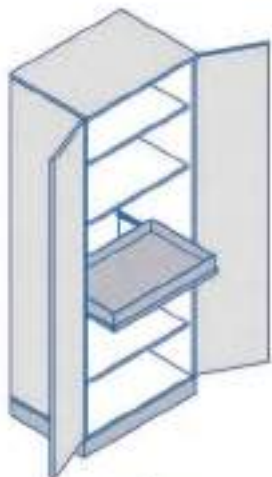

WASTE BIN

Can fit in a cabinets compartment with a minimum length of 300 mm and minimum width of 500 mm.

Standard sizes:

• **20 L:** 242x420x410 mm

• **2x15 L:** 248x480x400 mm

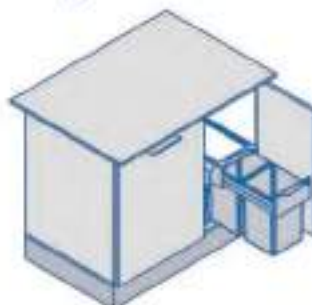



REAGENTS STORAGE UNITS

Special safety storage cabinets for chemical reagents: concentrated acids and bases, flammable organic solvents and gas cylinders.

For safety reasons, laboratory standards recommend storing reagents as following:

- **Flammables /organic solvent /explosible/ volatile substances**
(manufactured according the EN 14727 and EN 14470-1 norms).
- **Acids and bases:** It's highly recommended that these cabinets be equipped with a ventilation /carbon filtration system. The cabinets are manufactured according to the EN 14727 and EN 61010-1 norms.
- **Combined safety storage cabinets, both for flammables and acids** in separate compartments, manufactured according to the EN 14727, EN 14470-1 and EN 61010-1 norms.
- **Safety cabinets for indoor storage of gas cylinders**
in compliance with EN 14470-2 and EN 14727.



SECURITY · PROTECTION · VENTILATION
/FILTRATION SYSTEMS ACTIVATED CARBON FILTERS

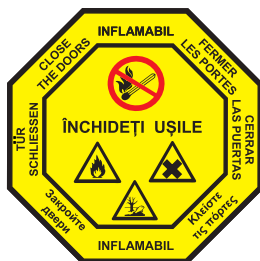

Warning sticker for cabinets containing liquid and solid flammable /explosive chemical products. Such cabinets may be placed inside the laboratories or in special reagent's storage room /warehouse.



Warning sticker for cabinets containing highly corrosive (acids and bases) chemical products. Such cabinets may be placed inside the laboratories or in the reagent's storage room or warehouse.



Warning sticker for cabinets containing highly concentrated pesticides and plant-protection substances (solid and liquid). It's recommended that cabinets are made of water and moisture-resistant materials.

Aspirated and filtered safety cabinets for the storage of chemical, acid and base products

Relevant standards and norms:

EN 14727:2006, EN 61010-1:2010

- Completely produced in pickled and electrogalvanized steel acid-proof powder-coated. External monolithic construction completely sealed. Palletized base: design of the base for easier transportation of the cabinet.
- Three tray-shaped removable shelves adjustable in height made of electrogalvanized steel acid-proof epoxy powder-coated; shelves with anti-falling security lock. Collection capacity of the shelf approx. 15 L.
- Watertight bottom basin in electrogalvanized steel acid-proof epoxy powder-coated.
- Doors opening up to 110° to allow an easy extraction of the shelves without tilting them. Acid-proof hidden hinges.
- Key lock with extractable cylinder.
- Equipped with energy saving system that adjusts fan speed to the state of the cabinet (open vs. closed), thereby allowing energy saving in safety conditions.
- Activated charcoal filter positioned inside the cabinet, easy to be replaced. Equipped with electronic device for charcoal filter replacement.
- Thermally protected electro aspirator made of class V0 polymer to grant the highest level of self-extinguishing, in compliance with EN 60335-1, EN 60335-2-80 and EN 50366 norms.
- "Danger" warning stickers on doors (as per EN DIN 4844 and ISO 3864).
- Grounding connection to discharge build-up of static electricity.
- Levelling feet for balance.
- Usage and maintenance manual.
- Packaging with "Tipping over system®" device.

Optional:

Cabinets can also be ordered with glass doors.



AA 1200 NEW

Standard sizes

External dimensions - 2 full doors (mm)	1200x500x1998
Internal dimensions (mm)	1120x450x1500
Weight (kg)	155
Loading capacity (kg)	100



AA 600

Standard sizes

External dimensions - 1 full door (mm)	600x500x1998
Internal dimensions (mm)	530x450x1500
Weight (kg)	95
Loading capacity (kg)	100

Storage units for flammables /organic solvents /explosive volatile reagents

Relevant standards and norms: EN 14470-1, EN 14727

- Storage unit made in pickled steel, acid-proof epoxy powder-coated.
- External monolithic construction completely sealed, with double cases, internal and external with fireproof insulation made of highly fire resistant material, completely ecological.
- Inflatable trimming that swells in case of fire, isolating the inside of the cabinet from the outside. With safety closing system with spring: in case of fire, automatically closes the door at a temperature of >50°C. Not electric.
- Internal body panels made of anti-scratch material, resistant to corrosive products.
- Natural internal ventilation system for vapours, equipped with two certified security valves for air recycling with automatic closure at 70°C.
- Three removable tray shaped shelves adjustable in height made of electrogalvanized steel acid-proof epoxy powder-coated. Removable and adjustable shelves with anti-falling security lock by rack.
- Collection capacity of the shelf approx. 7 L
Loading capacity 80 kg.
- Watertight bottom basin in electrogalvanized steel acid-proof epoxy powder-coated.
- Opening with no external hinges, anti-spark.
Key lock with **extractable cylinder**.
- "No smoking" and "Fire" warning stickers on doors (as per EN DIN 4844 and ISO 3864).
- Grounding connection to discharge build-up of static electricity and levelling feet for balance.



AC 1200 S



AC 600 S



AC 1200 CM



AC 600 CM

Standard sizes

	AC 1200 S	AC 600 S	AC 1200 CM	AC 600 CM
External dimensions (mm)	2 full doors 1200x640x1950	1 full door 680x640x1950	2 full doors 1180x640x1950	1 full door 680x640x1950
Internal dimensions (mm)	1053x495x1731	533x495x1731	1015x445x1685	515x445x1685
Weight (kg)	380	252	490	350
Loading capacity (kg)	80	80	80	80



Combined safety storage cabinets, both for flammables and acids (in separate sealed compartments)

Relevant standards and norms:

EN 61010-1, EN 14727, EN 14470-1, CE mark

- Completely produced in pickled and electrogalvanized steel acid-proof epoxy powder-coated.
- External monolithic construction completely sealed. Built with double cases, internal and external. "Danger" stickers for corrosive, harmful and toxic products on the chemicals compartment and "No Smoking" and "Fire" warning stickers on the flammables compartment, as required by EN DIN 4844 and ISO 3864.
- Locking system with key and cylinder lock.
- Grounding connection to discharge build-up of static electricity.
- Levelling feet for balance.

Upper compartment for chemical, acid and base products:

- Two tray-shaped removable shelves adjustable in height made of electrogalvanized steel acid-proof epoxy powder-coated. Shelves with anti-falling security lock. Door opening up to 110°, with hidden acid-proof hinges, allow an easy extraction of the shelves without tilting them. Activated charcoal filter positioned inside the cabinet, easy to be replaced and electronic device with sound alarm for charcoal filter replacement. Thermally protected electro aspirator in compliance with EN 60335-1, EN 60335-2-80 and EN 50366 norms, with 220 /230 V input, max absorbed power: 65 W and ON /OFF lamp.

Lower compartment for flammable products:

- Fireproof insulation made of highly fire resistant material, completely ecological. Internal body panels made of anti-scratch material, resistant to corrosive products. Inflatable trimming that swells in case of fire, isolating the inside of the cabinet from the outside. Extra inflatable trimming with protection against "Cold and Hot fumes" and dusts. Self-closing door with automatic return. Natural internal ventilation system for vapours, equipped with two certified security valves for air recycling with automatic closing mechanism above 70°C. The valves are positioned at the top and at the bottom of the rear wall of the cabinet in order to grant the release of substances, as per normative. External connection collar Ø100 mm.
- Watertight bottom basin in electrogalvanized steel acid-proof epoxy powder-coated, with perforated shelf.
- Safety catch that keeps the door closed in case of fire.
- Anti-spark hinges.



Kemfire 1100 A

Standard sizes

External dimensions - 2 full doors (mm)	1100x510x1670
Internal dimensions (mm)	490x465x1020 + 935x395x445
Weight (kg)	300
Loading capacity (kg)	80

Kemfire 600 A

Standard sizes

External dimensions - 1 full door (mm)	595x510x1750
Internal dimensions (mm)	510x474x924 + 430x355x537
Weight (kg)	185
Loading capacity (kg)	80

Safety cabinets for gas cylinders indoor storage

Relevant standards and norms: EN 14470-2, EN 14727

Storage cabinet for 2 or 4 gas cylinders (50 L).

- Completely made in pickled acid-proof epoxy powder-coated.
- External monolithic construction completely sealed. Made with double casing, internal and external.
- Fireproof insulation made of highly fire resistant material, completely ecological.
- Internal body panels made of anti-scratch material, resistant to corrosive products.
- Inflatable trimming that swells in case of fire, isolating the inside of the cabinet from the outside.
- Extra inflatable trimming with protection against "Cold and hot fumes" and dusts.
- Wing doors.
- Natural internal ventilation system for vapours, equipped with two certified security valves for air recycling with automatic closing system at +70°C. The valves are positioned at the top and at the bottom of the rear wall of the cabinet in order to grant the release of substances, as per normative. External connection collar Ø100 mm.
- Prepared for piping passage.
- Two gas cylinder brackets with locking chains.
- Rolling ramp to enable an easy placement of the cylinders in the cabinet.
- Prepared for safety device to detect gas leakages.
- Anti-spark hinges.
- Grounding connection to discharge build-up of static electricity.
- Levelling feet for balance.
- "No smoking" and "Fire" warning stickers on the door, as per EN.



BC 1350 GS

BC 650 GS

Standard sizes

External dimensions - 2 full doors (mm)	1300x600x2015
Internal dimensions (mm)	1165x500x1850
Weight (kg)	460

Standard sizes

External dimensions - 1 full door (mm)	700x600x2015
Internal dimensions (mm)	485x569x1850
Weight (kg)	300

Optional: With activated charcoal filters and fan



Custom storage cabinets for solids and low concentration acids



Relevant standards and norms: EN 14727

- Special storage cabinets for low concentration acids, bases and inorganic salts. Made of acid-proof materials.
- The cabinets are made of flame retardant melamine panels.
- Door /doors made in solid-grade HPL laminate – 12 mm thick, with hinges with opening up to 270°.
- Four metallic steel inner shelves (epoxy powder-coated) with adjustable height system.
Optional: Polypropylene or solid-grade compact HPL trays with sliders.
- Collector tray at the bottom of the cabinet, made of powder-coated steel.
- Prepared for exhaust /filtration pipe passage connection.

Standard sizes

One door compartment with locking mechanism (mm)

600x600x2000

Two doors with closing system (mm)

1100x600x2000



Custom storage cabinets for pesticides and phytosanitary chemicals



Relevant standards and norms: EN 14727

- Special storage cabinets for pesticides. Can be connected to ventilation system.
- The cabinets are entirely made of galvanized powder-coated steel.
- Door /doors with hinges opening up to 270°.
- Four metallic steel inner shelves (epoxy powder-coated) with adjustable height system.
Optional: Polypropylene or solid-grade compact HPL trays with sliders.
- Collector tray at the bottom of the cabinet, made of powder-coated steel.
- Prepared for exhaust /filtration pipe passage connection.

Standard sizes

One door compartment with locking mechanism (mm)	600x600x2000	Two doors with closing system (mm)	1100x600x2000
--------------------------------------------------	--------------	------------------------------------	---------------

CHEMICAL FUMEHOOD

Metallic freestanding fume cupboard with exhaust and filtration system and integrated under bench storage for chemical reagents according to EN 14175.

FUMEHOOD • FILTERS • EXHAUST SYSTEMS
REAGENT STORAGE • WORK SAFETY • AIRFLOW

The chemical fumehood – a protection equipment for laboratory use.
It's main roles are:

- **To control** user's exposure to gases, fumes, vapors aerosols and other dangerous airborne particles while operating laboratory procedures involving potentially harmful chemicals.
- **To prevent** the development of explosive clouds within the working area.
- **To protect** users in case of violent chemical reactions, explosions or splashes with dangerous substances

Operating principle: In order to ensure a contained hazardous perimeter within it's casing, negative pressure relative to surrounding environment is applied by connecting the fumehood to a complex exhaust system.



The fumehoods casing: Is made of electrostatic powder-coated steel. For ease of transportation and installation, the fumehood's body is made of easy to handle parts.

Work area: Is made of a contained protected space, with sealed walls and joints on all sides, accessible only from the front side, through a sliding vertical window – the sash. Opening the sash allows access for placing materials and equipment in the work area, so that the user can safely operate them. The sash opening can be adjusted at any height and has an automatic safety locking mechanism.

Control panel: It is ergonomically placed under the worktop and comprises the controllers for all utilities: electric sockets, lights, ventilation, etc.

Reagent storage body: Located beneath the workspace – for frequently used reagents and consumables, can be connected to the fumehoods main exhaust system.

Filters and ventilation: The exhaust system is powered by an electric single-phase /three-phase motor and centrifugal fan. In order to insure a constant airflow at the opening of the sash, the fumehood system has a controller unit that adjusts the fan speed to the opening of the sash. Filters: The filter system is made of active carbon plates.

INTENDED USE: Designed according to EN 14175, the fumehood is a safety laboratory equipment insuring safe work environment for operating laboratory staff.

CHEMICAL FUMEHOOD / NIȘA CHIMICĂ

1. Worktop: According to the intended laboratory activity – acid-proof, with drain sink and /or profiled overlapped anti-drip edges.

2. Storage units: Cabinets placed under the operating panel – for everyday reagents and consumables – can be connected to the main fumehood exhaust system.

3. Operating panel: Placed ergonomically right under the work area, holds together all switches and controllers for the fumehood supplies: light, ventilation, water /gas taps, etc.

a. Exhaust system: Controller with digital screen, assures a constant 0,5 m/s sash airflow, regardless if the sash is raised or lowered, according to **EN 14 175**. Equipped with acoustic sensor – audible warning system in case of low pressure /error.

b. AC plugs: IP44 with protection cover.

c. Faucets: Designed for laboratory use, with remote control valves, mounted on the control panel, and taps mounted on the deflector panel. Color code according to **EN 13 792:2002**.

3. Deflector panel: Safely guides the airflow.

4. Safety sash /work area: Work area is contained by acid-proof casing with sealed joints, front side of the fumehood with vertical sliding sash.

5. Body /case: The fumehoods casing is made of galvanized electrostatic powder-coated steel.

6. Filters: Are made of active carbon plates set up in special casings, easy to replace.

7. Ventilation and ducts: 230 /380 V with acid-proof or antiex ducts.

1. Blat de lucru: În funcție de activitate /aplicație – tratat antiacid, cu sau fără cuvă integrată și margine perimetrală antipicurare.

2. Dulap de stocare: Tratat antiacid pentru consumabile și substanțe utilizate frecvent, cu posibilitate de conectare la sistemul de exhaustare.

3. Panou de comandă: Așezat ergonomic sub blatul de lucru, cuprinde acționarea tuturor utilităților nișei: prize electrice, iluminat interior, robineti, acționare și monitorizare aspirație.

a. Ventilație: Controller cu afișaj digital – asigură un debit minim constant de 0,5 m /s la deschiderea sas-ului, indiferent dacă panoul glisant este coborât sau nu, conform SR EN 14175-6. Include senzor și avertizare sonoră în caz de avarie /debit scăzut.

b. Prize: IP44 cu capac de protecție.

c. Robineti: Speciali pentru uz în laborator, cu comandă la distanță, cu marcaj cromatic conform EN 13792:2002.

4. Panou deflector: Direcționează fluxul de aer viciat în procesul de aspirație.

5. Incintă de lucru /sas glisant: Incinta de lucru este capitonată cu materiale antiacide, etanșate, către fața nișei cu închidere prin panou glisant vertical.

6. Carcasă: Integral metalică, finisată prin vopsire în câmp electrostatic, complet demontabilă.

6. Filtre: Se compun din lastre de carbon activ în carcase speciale, ușor de înlocuit.

7. Ventilație și traseu de exhaustare: 230 /380 V și tubulatură antiacidă /antiex.

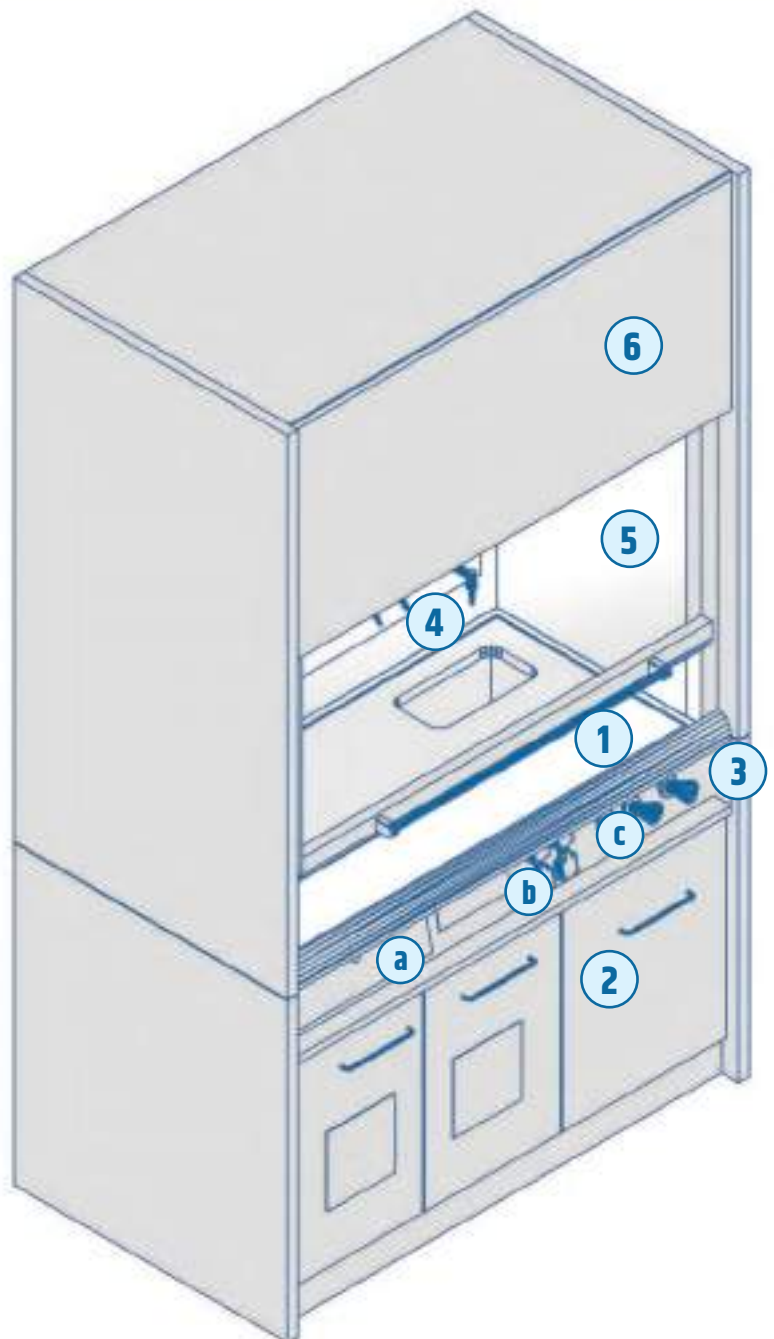



Standard sizes

Length (mm)	1050, 1350, 1650, 1950
Width (mm)	900
Height (mm)	2400

Worktop

Length (mm)	900, 1200, 1500, 1800
Width (mm)	600, 750, 900

Features

Ventilation	Standard	Optional
fan /ducts	acid-proof PP	
exhaust controller	ON /OFF button	Inverter i
power supply	tri-phase 380 V	mono-phase - 220 V
filters	for acids /bases or solvents	HEPA filter
Storage cabinets	Standard	Optional
two drawers cabinet	made of melamine panels / flame retardant melamine panels doors with additional HPL layer one /two doors compartment with 270° hinges	acid-proof shelves tray shaped shelves
1 - 3 doors (depending on length)	regular melamine shelves <hr/> metallic powder-coated cabinet one /two doors compartment with 270° hinges metal tray shaped shelves	ventilation
AC plugs	2 buc x 220 V	380 V plugs
Taps	1 water tap + controller 1 pcs gas + controller	taps for water, gas, N, vacuum, pure water, steam, etc.

Recommendation: Fumehood ducts material and filters are to be set according to the laboratory activity - these vary for acids /bases, solvents, etc. Exhaust performance can be affected by environment features such as nearby windows, doors and etc.

BIOLOGICAL SAFETY CABIN

CLASS II A2 BIOLOGICAL SAFETY CABIN

CHARACTERISTICS

- Biological safety cabinet type: CLASS II according to EN 12469 regulations. • Work area and work surface made of AISI 304 stainless steel.

The work surface is equipped with a drain for easy cleaning and collection of 4000 ml liquids with a drain valve for cleaning.

- Sliding front glass with alarm position. Activated by pedal, control board or remote.

- The recycled air is filtered by an absolute HEPA H14 filter (efficiency 99.995% MPPS EN1822 Regulation) and is sent to the work area at a speed of 0.50 m/s

- Partial air recirculation according to regulations: 30% expulsion and 70% recirculation.

- The air expelled to the outside is filtered by an independent absolute HEPA H14 filter (99.995% MPPS EN1822 Standard efficiency) dedicated for this purpose.

- Work area maintains laminar flow conditions with air purity type ISO 4 (According to ISO 14644) or Class 10 (according to Fed. Std. 209).

- Protection barrier in the work area with speed greater than 0.50 m/s.

- Microprocessor controlled cabin with updateable FLASH memory and external display for easy visualization of the cabin control parameters (speeds, flow rates, plenum pressure, expulsion barriers, etc...).

- Rubber end gasket to ensure watertightness

- The cabin comes equipped with an easy-to-use touch panel with a security key to control white/ultraviolet lighting, internal electrical outlet, gas valve and parameters. • Alarms to detect problems in the delivery system and the protection barrier due to negative pressure and door opening.

BSC-N 1100/1300/1500/1800/2000 models

BSC-NG 1300 models with side glass



Model BSC-N XXXX A2-X

- Exclusive fluorescent and UV lighting. • Working voltage 220 V. 50 Hz. Maximum current consumption 6 A. (approx. 1300 w.).

- As standard, the cabin includes UV light and LED lighting.; Electrical outlet of 110-220 volts depending on the client's needs. The UV light has a timer.

CLASS II A2 BIOLOGICAL SAFETY CABIN

Accesorios Opcionales:

- Gas intake with electronically controlled valve. vacuum intake
- Third stage filtration Active carbon for aerosol sprays.
- Unit support table.
- Peroxide decontamination connector
- Hydrogen and/or formalin.
- Side windows.
- Work surface divided into three sections (excludes liquid retention)

ADVANTAGES

CLASS II biological safety cabinet according to EN 12469-2000 and also meets the main NSF 49 requirements (Class II type A2/B3) and BS 5726/:2005

Monitoring and adjustment of clogging LCD display. All functions visible on the filters, minimizing the cost of the screen (laminarity, barriers, temperature, humidity, filter replacement of these. clogging, etc...)

Wide and curved armrest that Provides forearm comfort in any work position.

Remote control. All cabin functions can be controlled from six meters away, thus protecting the user in case of emergency.

Ergonomically tested, thanks to the noise level that is less than 50 dBA, below the level required by regulations 65 dBA.

BSC-N 1100/1300/1500/1800/2000 models

BSC-NG 1300 models with side glass



Model BSC-NG 1300 II A2 with side glass



CLASS II A2 BIOLOGICAL SAFETY CABIN

BSC-N 1100/1300/1500/1800/2000 models Model BSC-NG 1300 with side glass

ACCESSORIES

The options and accessories that can be requested are:

- Non-return valve.
- Additional active carbon filter to eliminate volatile chemical compounds and odors. There are different types of activated carbon.
- Hood type connection (canopy) for safe extraction.
- Formalin vaporizer for decontamination.
- Vaporizer for formalin neutralization.
- Solenoid valve for gas spigot, controlled from the panel of the Cabin.

- Plenum for double HEPA filtration in the extraction for extra safety when the unit expels air in the laboratory

- Hydrogen Peroxide decontamination connector.
- Spigots for gas, vacuum, air,....



Extraction hood



**Non-return valve
Formaldehyde**



**Plenum for double
filter**



Peroxide Connection



**Formaldehyde and
neutralization
vaporizers**

CLASS II A2 BIOLOGICAL SAFETY CABIN

BSC-N 1100/1300/1500/1800/2000 models Without side glass

TECHNICAL CHARACTERISTICS

MODEL	BSC-N-1100IIA2-X	BSC-N-1300IIA2-X	BSC-N-1500IIA2-X	BSC-N-1800IIA2-X	BSC-N-2000IIA2-X
Work area	940 x 600 x 660 1150 x 600 x 660 1350 x 600 x 660 1700 x 600 x 660 1800 x 600 x 660				
External dimensions (mm)	1100 x 750 x 1480 1300 x 750 x 1500 1500 x 750 x 1500 1873 x 775 x 1540 1950 x 800 x 1540				
Table dimensions (mm)	1100 x 750 x 760 1300 x 750 x 760 1500 x 700 x 760 1880 x 700 x 760 1950 x 700 x 760				
Transport dimensions (mm)	1250 x 1050 x 1870 1450 x 1050 x 1870 1640 x 1040 x 1860 1940 x 1050 x 1960 2090 x 1050 x 1860				
Weight (kg)	255	305	350	390	420
Material	Work area and work surface built in AISI 304 stainless steel				
Control system	Microprocessor with Flash memory				
Display	VFD display				
Main filter	Hepa H14 absolute filter with an efficiency of 99.995% mpps according to EN 1822 regulations				
Expulsion filter	Hepa H14 absolute filter with an efficiency of 99.995% mpps according to EN 1822 regulations				
Barrier	ÿ 0.50m/s				
Laminar flow	0.25m/s - 0.50m/s				
Air recirculation	70%				
Air Expulsion	30%				
Front glass	Automatic electronic sliding (Tempered safety glass)				
Air purity classification	Class 10				
Sound level	ÿ50db				
Lightning	> 1500 lux				
ultraviolet lamp	1 X 18W	1 X 18W	1 X 30W	1 X 40W	1 X 40W
Waste collection	ÿ 4000 ml with evacuation valve				
Power	220 v, 50 hz ± 10%				
Applied regulations	NSF 49, EN 12469				
Max consumption without plugs	300W	400W	700W	1000W	1200W
Consumption at work	150W	200W	250W	300W	400W
Reduced consumption	18W	18W	30W	40W	40W
Allowed consumption of plugs	1000W	1000W	1000W	1000W	1000W

REFERENCES FOR ORDERING

Code	Description
425-BSC-N-1100IIA2-X	High microbiological safety cabinet Type II C10 Mod. BSC-N-1100IIA2-X (70 - 30 %)
425-BSC-N-1300IIA2-X	High microbiological safety cabinet Type II C10 Mod. BSC-N-1300IIA2-X (70 - 30 %)
425-BSC-N-1500IIA2-X	High microbiological safety cabinet Type II C10 Mod. BSC-N-1500IIA2-X (70 - 30 %)
425-BSC-N-1800IIA2-X	High microbiological safety cabinet Type II C10 Mod. BSC-N-1800IIA2-X (70 - 30 %)
425-BSC-N-2000IIA2-X	High microbiological safety cabinet Type II C10 Mod. BSC-N-2000IIA2-X (70 - 30 %)

CLASS II A2 BIOLOGICAL SAFETY CABIN

Model BSC-NG 1300 With side glass

TECHNICAL CHARACTERISTICS

MODEL	BSC-NG-1300IIA2-X
Work area	1150x600x660
Exterior dimensions (mm)	1300x750x1500
Table dimensions (mm)	1300x750x680
Transport dimensions (mm)	1450 x 1050 x 1870
Side windows	YES
Weight (kg)	305
Material	Work area and work surface built in AISI 304 stainless steel
Control system	Microprocessor with Flash memory
Display	VFD display
Main filter	Hepa H14 absolute filter, 99.995% mpps efficiency according to EN 1822 regulations
Expulsion filter	Hepa H14 absolute filter, 99.995% mpps efficiency according to EN 1822 regulations
Barrier	> or = 0.50 m/s
Laminar flow	0.25m/s - 0.50m/s
Air recirculation	70%
Air Expulsion	30%
Front glass	Automatic electronic sliding (Tempered safety glass)
Air purity classification	Class 10
Sound level	ÿ50db
Lightning	ÿ 1500 lux
ultraviolet lamp	1 X 18W
Power	220 v, 50 hz ± 10%
Applied regulations Max.	NSF 49, EN 12469
consumption without plugs	400W
Consumption at work	200W
Reduced consumption	18W
Allowed consumption of plugs	1000W

REFERENCES FOR ORDERING

Code	Description
425-BSC-NG-1300IIA2	High microbiological security cabin C10 mod. BSC-N-1300IIA2-X glass walls

Model BSC-NG 1300





LABORATORY CHAIRS

Technological seating for laboratory use, made of special dedicated materials, washable, wear-resistant, fixed or on castors.

Laboratory chairs are made of special materials, in order to comply with the laboratories routine. Fixed or mobile, with seat, backrest and adjustable handles, technological seats are easy to clean with washable surfaces with castors suitable for running surface and /or leg support ring.

Depending on laboratory's activity, the lab chairs can be:

- **Common:** Stools and laboratory chairs, optionally with tall base and foot ring, for weighing /microscopy. Seat /backrest made of moisture resistant materials, washable, resistant to household and laboratory detergents and disinfectants.
- **Specially made for pharmaceutical laboratories:** GMP certified and /or clean rooms.
- **ESD:** Made of special materials for this type of activity, there are ESD materials with which the seat /backrest can be adjusted.



ERGONOMIC • WASHABLE • ESD • ADJUSTABLE

Standard:

- Black nylon star base, fixed or on castors
- Height adjustment – gas lift mechanism
- Without armrests

Optional:

- Metallic base
- Base with round metallic footrest
- Armrests
- ESD



LABORATORY CHAIRS

LABSIT

Medium height laboratory chair for general lab use – star shaped base in nylon, on castors.

The seat and backrest are fixed in a plastic shell with a handle the back for better handling. Both the seat and the seat rest:

- Can be made of hard polyurethane foam (washable and antibacterial surface, wear and shock resistant, stands regular washing with disinfectants and detergents).
- Can be upholstered in ecological leather (washable surface, stands regular cleaning with disinfectants and detergents, PVC-free, low maintenance).
- Can be upholstered in textile. Comfortable surface for long term use, wear-resistant).
- Supertec Textile – micro-plating texture, pleasant to touch, comfortable for long term use, cut proof, non-slip, easy to clean.

Standard sizes

Total height (mm)	770-810
Star base diameter (mm)	640
Seat height / (mm)	420-550
Seat width / (mm)	450
Seat depth / (mm)	420
Backrest height / (mm)	420





HOCKER

Swivel, high stool for laboratory use, comfortable, anti-slip seat made of black soft polyurethane, with adjustable height - gas lift.

Seat and backrest - non-slip, easy to clean polyurethane, antibacterial, resistant to abrasive and cleaning detergents.

Standard sizes

Total height / (mm)	510-830
Star base diameter / (mm)	600
Seat height / (mm)	390-700
Seat width / (mm)	320
Seat depth / (mm)	340



TECHNO

Swivel, medium height chair for laboratory use, comfortable, anti-slip seat made of black soft polyurethane, with adjustable height - gas lift.

Seat and backrest - Non-slip, easy to clean polyurethane, antibacterial, resistant to abrasive and cleaning detergents.

Standard sizes

Total height / (mm)	510-830
Star base diameter / (mm)	600
Seat height / (mm)	390-700
Seat Width / (mm)	430
Seat Depth / (mm)	440
Backrest / (mm)	360/410





MEDLAK SL - Avda. Virgen del Rocío S/N C.C. La Colonia local 18. 29670 San Pedro
Alcántara (Málaga)
Tel: +34 951 553 278 • Fax: +34 952 784 031
www.medlak.es • info@medlak.es

medlak
EQUIPOS DE LABORATORIO Y MEDICO